

HARRIS COUNTY FIRE CODE

AS

ADOPTED: September 14, 2004

EFFECTIVE: January 1, 2005

AMENDED: July 1, 2008

AMENDED: April 12, 2012

AMENDED: December 16, 2014

EFFECTIVE: March 1, 2015

AMENDED: April 30, 2019

EFFECTIVE: September 1, 2019

AMENDED: December 15, 2020

EFFECTIVE: February 1, 2021



**HARRIS COUNTY
ENGINEERING DEPARTMENT**

**JOHN R. BLOUNT, PE
COUNTY ENGINEER**



**HARRIS COUNTY
FIRE MARSHAL'S OFFICE**

**LAURIE L. CHRISTENSEN CFPS, FM, FEMT
HARRIS COUNTY FIRE MARSHAL
FIRE CODE OFFICIAL**

TABLE OF CONTENTS

SECTION 101 – SCOPE AND GENERAL REQUIREMENTS	03
SECTION 102 – APPLICABILITY	05
SECTION 103 – DEPARTMENT OF FIRE CODE ADMINISTRATION AND ENFORCEMENT	07
SECTION 104 – GENERAL AUTHORITY AND RESPONSIBILITIES	08
SECTION 105 – PERMITS	12
SECTION 106 – FEES	29
SECTION 107 – INSPECTIONS	30
SECTION 108 – MAINTENANCE	31
SECTION 109 – BOARD OF APPEALS	32
SECTION 110 – VIOLATIONS	33
SECTION 111 – UNSAFE BUILDINGS	35
SECTION 112 – STOP WORK ORDER	36
SECTION 113 – SERVICE UTILITIES	37
EXHIBIT A – ADDITIONS, INSERTIONS, DELETIONS AND CHANGES to INTERNATIONAL FIRE CODE.	38
EXHIBIT B – ADDITIONS, INSERTIONS, DELETIONS AND CHANGES to INTERNATIONAL BUILDING CODE.	81

Harris County has only adopted certain chapters of the International Building Code. Please refer to **102.4 Application of building code** for chapters and sections that have been adopted.

CHAPTER 1

SCOPE AND ADMINISTRATION

PART 1—GENERAL PROVISIONS

SECTION 101

SCOPE AND GENERAL REQUIREMENTS

101.1 Title. These regulations shall be known as the *Fire Code* of Harris County, hereinafter referred to as “this code.”

101.1.1 Occupancy prohibited before approval. No building or structure subject to this code shall be occupied prior to:

1. Receipt by the County Fire Code Official of a request for final inspection from the permit Holder as submitted on a form provided by the County Engineer, and
2. Issuance of a Certificate of Compliance by the County Engineer that indicates that applicable provisions of this code have been met.

This Code is adopted as a fire code by the Commissioners Court of Harris County, Texas, acting in its capacity as the governing body of Harris County. The authority of Harris County to adopt this Code and the contents hereof is derived from Chapter 233, Subchapter C, Texas Local Government Code, Section, §233.061 et seq., as amended. The Harris County Fire Code as adopted on September 14, 2004 and which became effective on January 1, 2005 shall continue to apply to the construction of buildings for which construction begins prior to the effective date of this new Code. This Code shall apply to all buildings for which Construction or Substantial Improvement, as defined in this Code, begins after the effective date of this Fire Code. Further, pursuant to Texas Local Government Code 352.016, as amended, any inspection completed shall be to the standard set forth in this Code. This Code may be amended at any time by a majority of Commissioners Court.

101.2 Scope. This code establishes regulations affecting or relating to structures, processes, premises and safeguards regarding all of the following:

1. The hazard of fire and explosion arising from the storage, handling or use of structures, materials or devices.
2. Conditions hazardous to life, property or public welfare in the occupancy of structures or premises.
3. Fire hazards in the structure or on the premises from occupancy or operation.
4. Matters related to the construction, extension, repair, alteration or removal of fire suppression or alarm systems.
5. Conditions affecting the safety of fire fighters and emergency responders during emergency operations.
6. New construction, substantial improvements, alterations, relocations, enlargement, replacement, repair, equipment, use and occupancy, location, of every building or structure or any appurtenances connected or attached to such buildings or structures.
7. Existing single-family dwelling converted for the use of a Boarding or Lodging House as defined in this code and in compliance with Local Government Code 233 Subchapter F “Residential Building Code”.

Exceptions:

1. One-and-two-family dwellings and multiple single family dwellings (townhouses) not more than three stories above grade plane in height with a separate means of egress, and their accessory structures not more than three stories above grade plane height, shall comply with Local Government Code 233 Subchapter F “Residential Building Code”.
2. Industrial facilities having a fire brigade that conforms to requirements of the Occupational Safety and Health Administration 1910 and receives exemption by Harris County.

101.2.1 Appendices. Appendices B, C, D, H and I are adopted as part of the Harris County Fire Code.

101.3 Intent. The purpose of this code is to establish the minimum requirements consistent with nationally recognized good practice for providing a reasonable level of life safety and property protection from the hazards of fire, explosion or dangerous conditions in new and existing buildings, structures and premises, and to provide a reasonable level of safety to fire fighters and emergency responders during emergency operations.

101.4 Severability. If a section, subsection, sentence, clause or phrase of this code is, for any reason, held to be unconstitutional, such decision shall not affect the validity of the remaining portions of this code.

101.5 Validity. In the event any part or provision of this code is held to be illegal or void, this shall not have the effect of making void or illegal any of the other parts or provisions hereof, which are determined to be legal; and it shall be presumed that this code would have been adopted without such illegal or invalid parts or provisions.

101.6 Abrogation and greater restrictions. This Code is not intended to repeal, abrogate, or impair any existing laws, regulations, easements, covenants, or deed restrictions.

SECTION 102
APPLICABILITY

102.1 Construction and design provisions. The construction and design provisions of this code shall apply to:

1. Structures, facilities and conditions arising after the adoption of this code.
2. Existing structures, facilities and conditions not legally in existence at the time of adoption of this code.
3. Existing structures, facilities and conditions where required in Chapter 11.
4. Existing structures, facilities and conditions that, in the opinion of the *fire code official*, constitute a distinct hazard to life or property.

102.2 Administrative, operational and maintenance provisions. The administrative, operational and maintenance provisions of this code shall apply to:

1. Conditions and operations arising after the adoption of this code.
2. Existing conditions and operations.

102.3 Substantial Improvement. A substantial improvement shall not be made unless the building and/or structure is made to comply with new construction requirements of the Harris County Fire Code.

102.3.1 Use and Occupancy. No building or structure shall be used or occupied, and no change in the existing occupancy classification or use of a building or structure or portion thereof shall be made, until a fire code inspection has been completed as approved and the County Engineer has issued a certificate of compliance as provided herein. Issuance of a certificate of compliance shall not be construed as an approval of a violation of the provisions of this code or of other regulations, ordinances, or court orders of Harris County, Texas.

Exception: Certificates of compliance are not required for work exempt.

102.4 Application of building code. The design and construction of new structures shall comply with Chapters 2-10, 30, 35, and Sections 1405, 1505, 1705.14 through 1705.18, 2403, 2406 through 2409, 3101 through 3105, 3110, 3111, 3301, 3302, 3306, 3307, 3309 through 3314 and Appendix C of the *International Building Code*, and any *alterations*, additions, substantial improvements, changes in occupancy, use or changes in structures required by this code, which are within the scope of the *International Building Code*, shall be made in accordance therewith.

102.5 Application of residential code. Regulated by the State of Texas and the Regulations of Harris County, Texas for the Approval and Acceptance of Infrastructure (“Infrastructure Regulations”).

102.6 Historic buildings. The provisions of this code relating to the construction, *alteration*, repair, enlargement, restoration, relocation or moving of buildings or structures shall not be mandatory for existing buildings or structures identified and classified by the state or local jurisdiction as historic buildings where such buildings or structures do not constitute a distinct hazard to life or property. Fire protection in designated historic buildings shall be provided with an *approved* fire protection plan as required in Section 1103.1.1.

102.7 Referenced codes and standards. The codes and standards referenced in this code shall be those that are listed in Chapter 80, and such codes and standards shall be considered to be part of the requirements of this code to the prescribed extent of each such reference and as further regulated in Sections 102.7.1 and 102.7.2.

102.7.1 Conflicts. Where conflicts occur between provisions of this code and referenced codes and standards, the provisions of this code shall apply.

102.7.2 Provisions in referenced codes and standards. Where the extent of the reference to a referenced code or standard includes subject matter that is within the scope of this code, the provisions of this code, as applicable, shall take precedence over the provisions in the referenced code or standard.

102.8 Subjects not regulated by this code. Where applicable standards or requirements are not set forth in this code, or are contained within other laws, codes, regulations, ordinances or bylaws adopted by the jurisdiction, compliance with applicable standards of the National Fire Protection Association or other nationally recognized fire safety standards, as *approved*, shall be deemed as prima facie evidence of compliance with the intent of this code. Nothing herein shall derogate from the authority of the *fire code official* to determine compliance with codes or standards for those activities or installations within the *fire code official's* jurisdiction or responsibility.

102.9 Matters not provided for. Requirements that are essential for the public safety of an existing or proposed activity, building or structure, or for the safety of the occupants thereof, that are not specifically provided for by this code, shall be determined by the *fire code official* and County Engineer.

102.10 Conflicting provisions. Where there is a conflict between a general requirement and a specific requirement, the specific requirement shall be applicable. Where, in a specific case, different sections of this code specify different materials, methods of construction or other requirements, the most restrictive shall govern.

102.11 Other laws. The provisions of this code shall not be deemed to nullify any provisions of local, state or federal law.

102.12 Application of references. References to chapter or section numbers, or to provisions not specifically identified by number, shall be construed to refer to such chapter, section or provision of this code.

PART 2—ADMINISTRATIVE PROVISIONS

SECTION 103

DEPARTMENT OF FIRE CODE ADMINISTRATION AND ENFORCEMENT

103.1 General. The County Engineer means the individual appointed by Commissioner’s Court and all employees designated by the County Engineer to administer the provision of this code to include the review of submitted construction plans and documents for compliance with this adopted code and the issuance of the required permits and final Certificates of Compliance.

The *fire code official* shall be the person appointed by Commissioners Court as the County Fire Marshal or the employee(s) designated by the County Fire Marshal to perform a task required by this code. The Fire Marshal shall have enforcement authority for this code and shall conduct all required inspections for compliance with this code.

103.2 Appointment. The County Engineer and County Fire Marshal shall be appointed by the Commissioner’s Court of Harris County.

103.3 Deputies. In accordance with the prescribed procedures of this jurisdiction and with the concurrence of the appointing authority.

103.3.1 Fire Code Official. Fire Code Official shall have the authority to appoint deputies, other related technical officers, inspectors and other employees.

103.3.2 County Engineer. County Engineer shall have the authority to appoint a Building Official, other related technical officers, and other employees.

103.4 Liability. The *fire code official*, County Engineer, member of the board of appeals, officer or employee charged with the enforcement of this code, while acting for the jurisdiction, in good faith and without malice in the discharge of the duties required by this code or other pertinent law or ordinance, shall not thereby be rendered civilly or criminally liable personally, and is hereby relieved from all personal liability for any damage accruing to persons or property as a result of an act or by reason of an act or omission in the discharge of official duties.

103.4.1 Legal defense. Any suit or criminal complaint instituted against any officer or employee because of an act performed by that officer or employee in the lawful discharge of duties and under the provisions of this code shall be defended by the legal representatives of the jurisdiction until the final termination of the proceedings. The *fire code official*, County Engineer, or any subordinate shall not be liable for costs in an action, suit or proceeding that is instituted in pursuance of the provisions of this code; and any officer of Harris County, acting in good faith and without malice, shall be free from liability for acts performed under any of its provisions or by reason of any act or omission in the performance of official duties in connection therewith.

SECTION 104

GENERAL AUTHORITY AND RESPONSIBILITIES

104.1 General. The County Engineer in cooperation with the *fire code official* is hereby authorized to administrate and enforce the provisions of this code. The County Engineer and *fire code official* shall have the authority to render interpretations of this code and to adopt policies, procedures, rules and regulations in order to clarify the application of its provisions. Such interpretations, policies, procedures, rules and regulations shall be in compliance with the intent and purpose of this code. Such policies, procedures, rules and regulations shall not have the effect of waiving requirements specifically provided for in this code.

104.1.1 Authority of the Fire Marshal and the Fire Marshal's Office. It shall be the duty of the Fire Marshal or designee to protect the safety and property of residents from fire hazards, through the issuance of Fire Marshal Orders, Notices of Violations, and Citations as required to achieve compliance with the fire and building codes.

104.2 Applications and permits. The County Engineer is authorized to receive applications, review *construction documents* and issue permits for construction regulated by this code, issue permits for operations regulated by this code. The *fire code official* is authorized to inspect the premises for which such permits have been issued and enforce compliance with the provisions of this code.

104.3 Right of entry. Where it is necessary to make an inspection to enforce the provisions of this code, or where the *fire code official* has reasonable cause to believe that there exists in a building or on any premises any conditions or violations of this code that make the building or premises unsafe, dangerous or hazardous, the *fire code official* shall have the authority to enter the building or premises at all reasonable times to inspect or to perform the duties imposed on the *fire code official* by this code. If such building or premises is occupied, the *fire code official* shall present credentials to the occupant and request entry. If such building or premises is unoccupied, the *fire code official* shall first make a reasonable effort to locate the *owner*, the *owner's* authorized agent or other person having charge or control of the building or premises and request entry. If entry is refused, the *fire code official* has recourse to every remedy provided by law to secure entry.

104.3.1 Warrant. Where the *fire code official* has first obtained a proper inspection warrant or other remedy provided by law to secure entry, an *owner*, the *owner's* authorized agent or occupant or person having charge, care or control of the building or premises shall not fail or neglect, after proper request is made as herein provided, to permit entry therein by the *fire code official* for the purpose of inspection and examination pursuant to this code.

104.3.2 Photographic Documentation. Members of the Fire Marshal's Office making such examinations or inspections are authorized to, upon presentation of proper credentials, take audio recordings, video recordings, or photographs, for evidence and for records for use by the Fire Marshal's Office to document and study fire hazards and scientific control for fire safety.

104.4 Identification. The *fire code official* shall carry proper identification when inspecting structures or premises in the performance of duties under this code.

104.5 Notices and orders. The *fire code official* is authorized to issue such notices or orders as are required to affect compliance with this code in accordance with Sections 110.1 and 110.2.

104.6 Official records. The County Engineer and *fire code official* shall keep official records as required by Sections 104.6.1 through 104.6.4. Such official records shall be retained for not less than 5 years or for as long as the structure or activity to which such records relate remains in existence, unless otherwise provided by other regulations.

104.6.1 Approvals. A record of approvals shall be maintained by the County Engineer and shall be available for public inspection during business hours in accordance with applicable laws.

104.6.2 Inspections. The *fire code official* shall keep a record of each inspection made, including notices and orders issued, showing the findings and disposition of each.

104.6.3 Fire records. The fire department shall keep a record of fires occurring within its jurisdiction and of facts concerning the same, including statistics as to the extent of such fires and the damage caused thereby, together with other information as required by their governing body.

104.6.4 Administrative. Application for modification, alternative methods or materials and the final decision of the County Engineer and *fire code official* shall be in writing and shall be officially recorded in the permanent records of the County Engineer and *fire code official*.

104.7 Approved materials and equipment. Materials, equipment and devices *approved* by the County Engineer and *fire code official* shall be constructed and installed in accordance with such approval.

104.7.1 Material and equipment reuse. Materials, equipment and devices shall not be reused or reinstalled unless such elements have been reconditioned, tested and placed in good and proper working condition and *approved*.

104.7.2 Technical assistance. To determine the acceptability of technologies, processes, products, facilities, materials and uses attending the design, operation or use of a building or premises subject to inspection by the *fire code official*, the County Engineer and *fire code official* is authorized to require the *owner* or *owner's* authorized agent to provide, without charge to the jurisdiction, a technical opinion and report. The opinion and report shall be prepared by a qualified engineer, specialist, and laboratory or fire safety specialty organization acceptable to the County Engineer and *fire code official* and shall analyze the fire safety properties of the design, operation or use of the building or premises and the facilities and appurtenances situated thereon, to recommend necessary changes. The County Engineer and *fire code official* are authorized to require design submittals to be prepared by, and bear the stamp of, a registered design professional.

104.8 Modifications. Where there are practical difficulties involved in carrying out the provisions of this code, the County Engineer and *fire code official* shall have the authority to grant modifications for individual cases, provided that the County Engineer and *fire code official* shall first find that special individual reason makes the strict letter of this code impractical and the modification is in compliance with the intent and purpose of this code and that such modification does not lessen health, life and fire safety requirements. The details of action granting modifications shall be recorded and entered in the files of the *fire code official* and County Engineer.

104.9 Alternative materials, design and methods of construction and equipment. The provisions of this code are not intended to prevent the installation of any material or to prohibit any design or method of construction not specifically prescribed by this code, provided that any such alternative has been *approved*. An alternative material, design or method of construction shall be approved where the County Engineer and *fire code official* finds that the proposed design is satisfactory and complies with the intent of the provisions of this code, and that the material, method or work offered is, for the purpose intended, not less than the equivalent of that prescribed in this code in quality, strength, effectiveness, *fire resistance*, durability and safety. Where the alternative material, design or method of construction is not

approved, the County Engineer and *fire code official* shall respond in writing, stating the reasons why the alternative was not approved.

104.9.1 Research reports. Supporting data, where necessary to assist in the approval of materials or assemblies not specifically provided for in this code, shall consist of valid research reports from *approved* sources.

104.9.2 Tests. Where there is insufficient evidence of compliance with the provisions of this code, or evidence that a material or method does not conform to the requirements of this code, or in order to substantiate claims for alternative materials or methods, the County Engineer and *fire code official* shall have the authority to require tests as evidence of compliance to be made without expense to the jurisdiction. Test methods shall be as specified in this code or by other recognized test standards. In the absence of recognized and accepted test methods, the County Engineer and *fire code official* shall approve the testing procedures. Tests shall be performed by an *approved* agency. Reports of such tests shall be retained by the County Engineer and *fire code official* for the period required for retention of public records.

104.10 Fire investigations. The Fire Marshal shall have the authority to investigate the cause, origin and circumstances of any fire, explosion or other hazardous condition. Information that could be related to trade secrets or processes shall not be made part of the public record, except as directed by a court of law.

104.10.1 Assistance from other agencies. Police and other enforcement agencies shall have authority to render necessary assistance in the investigation of fires when requested to do so by the Fire Marshal.

104.11 Authority at fires and other emergencies. The fire chief or officer of the fire department in charge at the scene of a fire or other emergency involving the protection of life or property, or any part thereof, shall have the authority to direct such operation as necessary to extinguish or control any fire, perform any rescue operation, investigate the existence of suspected or reported fires, gas leaks or other hazardous conditions or situations, or take any other action necessary in the reasonable performance of duty. In the exercise of such power, the Fire Marshal or fire chief is authorized to prohibit any person, vehicle, vessel or thing from approaching the scene, and is authorized to remove, or cause to be removed or kept away from the scene, any vehicle, vessel or thing that could impede or interfere with the operations of the fire department and, in the judgment of the fire chief, any person not actually and usefully employed in the extinguishing of such fire or in the preservation of property in the vicinity thereof.

104.11.1 Barricades. The Fire Marshal, fire chief or officer of the fire department in charge at the scene of an emergency is authorized to place ropes, guards, barricades or other obstructions across any street, alley, place or private property in the vicinity of such operation so as to prevent accidents or interference with the lawful efforts of the fire department to manage and control the situation and to handle fire apparatus.

104.11.2 Obstructing operations. Persons shall not obstruct the operations of the fire department in connection with extinguishment or control of any fire, or actions relative to other emergencies, or disobey any lawful command of the Fire Marshal, fire chief or officer of the fire department or Fire Marshal in charge of the emergency, or any part thereof, or any lawful order of a police officer assisting the fire department.

104.11.3 Systems and devices. Persons shall not render a system or device inoperative during an emergency unless by direction of the Fire Marshal, fire chief or fire department official in charge of the incident.

104.11.4 Removal of debris and rubble after fires. Whenever any building, structure, or other property in the county is partially burned, the owner or the person in charge or control thereof, shall within ten (10) days after notice from the Fire Marshal, remove all refuse, debris, charred, and partially burned lumber and materials from the ground. If a building or other structure is burned to such an extent that it is rendered unrepairable, the owner of the property upon which structure is located, or owner's authorized agent, shall within thirty (30) days after notice from the Fire Marshal, remove all remaining portions of the building or structure, from the property.

SECTION 105

PERMITS

105.1 General. Permits shall be in accordance with Sections 105.1.1 through 105.7.25.

105.1.1 Permits required. A property owner or owner's authorized agent who intends to conduct an operation or business, or construct, substantially improve, enlarge, alter, repair, move, or change the occupancy of a building or structure, or to erect, install, enlarge, alter, repair, remove, convert, or replace the installation of which is regulated by this code, or to cause any such work to be performed, shall first make application to the County Engineer and obtain the required permit.

105.1.2 Types of permits. There shall be two types of permits as follows:

1. Operational permit. An operational permit allows the applicant to conduct an operation or a business for which a permit is required by Section 105.6 for either:

1.1. A prescribed period.

1.2. Until renewed or revoked.

2. Construction permit. A construction permit allows the applicant to construct, substantially improve, enlarge, alter, repair, move, or change the occupancy of a building or structure, or to erect, install, enlarge, alter, repair, remove, convert, or replace the installation of which is regulated by this code, or to cause any such work to be performed, or install or modify systems and equipment for which a permit is required.

105.1.3 Multiple permits for the same location. Where more than one permit is required for the same location, the County Engineer is authorized to consolidate such permits into a single permit provided that each provision is listed in the permit.

105.1.4 Emergency repairs. Where equipment replacement and repairs must be performed in an emergency situation, the permit application shall be submitted within the next working business day to the County Engineer.

105.1.5 Repairs. Application or notice to the *fire code official* and County Engineer is not required for ordinary repairs to structures, equipment or systems. Such repairs shall not include the cutting away of any wall, partition or portion thereof, the removal or change of any required *means of egress*, or rearrangement of parts of a structure affecting the egress requirements; nor shall any repairs include addition to, alteration of, replacement or relocation of any standpipe, fire protection water supply, *automatic sprinkler system*, fire alarm system or other work affecting fire protection or life safety.

105.1.5.1 Fire Protection Repairs. The Fire Marshal shall be notified in accordance with State rules of any repairs or impairments to any fire protection systems.

105.1.6 Annual permit. Instead of an individual construction permit for each alteration to an already *approved* system or equipment installation, the County Engineer is authorized to issue an annual permit on application therefor to any person, firm or corporation regularly employing one or more qualified tradespersons in the building, structure or on the premises owned or operated by the applicant for the permit.

105.1.6.1 Annual permit records. The person to whom an annual permit is issued shall keep a detailed record of alterations made under such annual permit. The County Engineer and *fire code official* shall have access to such records at all times or such records shall be filed with the *fire code official* as designated.

105.2 Application. Application for a permit required by this code shall be made to County Engineer in such form and detail as prescribed by the County Engineer. Applications for permits shall be accompanied by such plans as prescribed by the County Engineer.

105.2.1 Refusal to issue permit. If the application for a permit describes a use that does not conform to the requirements of this code and other pertinent laws and ordinances, the County Engineer shall not issue a permit, but shall return the application to the applicant with the refusal to issue such permit. Such refusal shall, where requested, be in writing and shall contain the reasons for refusal.

105.2.2 Inspection authorized. Before a new operational permit is *approved*, the *fire code official* is authorized to inspect the receptacles, vehicles, buildings, devices, premises, storage spaces or areas to be used to determine compliance with this code or any operational constraints required.

105.2.3 Time limitation of application. An application for a permit for any proposed work or operation shall be deemed to have been abandoned 180 days after the date of filing, unless such application has been diligently prosecuted or a permit shall have been issued; except that the County Engineer is authorized to grant one or more extensions of time for additional periods not exceeding ninety (90) days each. The extension shall be requested in writing and justifiable cause demonstrated.

105.2.4 Action on application. The County Engineer shall examine or cause to be examined applications for permits and amendments thereto within a reasonable time after filing. If the application or the *construction documents* do not conform to the requirements of pertinent laws, the County Engineer shall reject such application in writing, stating the reasons therefor. If the County Engineer is satisfied that the proposed work or operation conforms to the requirements of this code and laws and ordinances applicable thereto, the County Engineer shall issue a permit therefor as soon as practicable.

105.2.5 Working without a permit. Work requiring a permit shall not commence until the required permit is posted in a conspicuous location and approved plans are available on the premises designated therein. Where work is commenced prior to obtaining said permit, the fees may be increased as determined by the fee schedule adopted by Commissioners Court. Payment of the increased fee shall not relieve any person from fully complying with the requirements to obtain a permit nor of any other penalties herein.

105.3 Conditions of a permit. A permit shall constitute permission to maintain, store or handle materials; or to conduct processes that produce conditions hazardous to life or property; or to install equipment utilized in connection with such activities; or to install or modify any *fire protection system* or equipment or any other construction, equipment installation or modification in accordance with the provisions of this code where a permit is required by Section 105.6 or 105.7. Such permission shall not be construed as authority to violate, cancel or set aside any of the provisions of this code or other applicable regulations or laws of the jurisdiction.

105.3.1 Expiration. An operational permit shall remain in effect until reissued, renewed or revoked, or for such a period of time as specified in the permit. Construction permits shall automatically become invalid unless the work authorized by such permit is commenced within 180 days after its issuance, or if the work authorized by such permit is suspended or abandoned for a period of 180 days after the time the work is commenced. Before such work recommences, a new permit shall be first obtained and the fee to recommence work, if any, shall be one-half the amount required for a new permit for such work, provided that changes have not been made and will not be made in the original construction documents for such work, and provided further that such suspension or abandonment

has not exceeded one year. Permits are not transferable and any change in occupancy, operation, tenancy or ownership shall require that a new permit be issued.

105.3.2 Extensions. A permittee holding an unexpired permit shall have the right to apply for an extension of the time within which the permittee will commence work under that permit where work is unable to be commenced within the time required by this section for good and satisfactory reasons. The County Engineer is authorized to grant, in writing, up to two extensions of the time period of a permit for periods of not more than 180 days each. Such extensions shall be requested by the permit holder in writing and justifiable cause demonstrated.

105.3.3 Occupancy prohibited before approval. The building or structure shall not be occupied prior to the County Engineer issuing a permit and the *fire code official* conducting associated inspections indicating the applicable provisions of this code have been met.

105.3.4 Conditional Certificate of Compliance. Where permits are issued and on the request of a permit applicant, the *fire code official* is authorized to issue a conditional certificate of compliance to occupy the premises or portion thereof before the entire work or operations on the premises is completed, provided that such portion or portions will be occupied safely prior to full completion or installation of equipment and operations without endangering life or public welfare. The *fire code official* shall notify the permit applicant in writing of any limitations or restrictions necessary to keep the permit area safe. The holder of a conditional certificate of compliance shall proceed only to the point for which approval has been given, at the permit holder's own risk and without assurance that approval for the occupancy or the utilization of the entire premises, equipment or operations will be granted.

105.3.5 Posting the permit. Issued permits shall be kept on the premises designated therein at all times and shall be readily available for inspection by the *fire code official* and County Engineer. When a permit or approved plans are not on site or available upon request of the *fire code official* or designee, the owner of the permit or designee may be assessed a fee prior to any additional inspections.

105.3.6 Compliance with Code. The issuance or granting of a permit shall not be construed to be a permit for, or an approval of, any violation of any of the provisions of this Code or of any other regulation or ordinance of Harris County. Permits presuming to give authority to violate or cancel the provisions of this Code or other regulation or ordinances of Harris County shall not be valid. The issuance of a permit based on *construction documents* and other data shall not prevent the *fire code official* or County Engineer from requiring the correction of errors in the *construction documents* and other data. Any addition to or alteration of *approved construction documents* shall be *approved* in advance by the County Engineer, as evidenced by the issuance of a new or amended permit.

105.3.7 Information on the permit. The County Engineer shall issue all permits required by this code on an *approved* form furnished for that purpose. The permit shall contain a general description of the operation or occupancy and its location and any other information required by the County Engineer. Issued permits shall bear the signature of the County Engineer or other *approved* legal authorization.

105.3.8 Validity of permit. The issuance or granting of a permit shall not be construed to be a permit for, or an approval of, any violation of any of the provisions of this Code or of any other regulation or ordinances of Harris County. Permits presuming to give authority to violate or cancel the provisions of this Code or other regulation or ordinances of Harris County shall not be valid. The issuance of a permit based on *construction documents*, operational documents and other data shall not prevent the *fire code official* or the County Engineer from requiring correction of errors in the documents or other data.

105.4 Construction documents. *Construction documents* shall be in accordance with Sections 105.4.1 through 105.4.6.

105.4.1 Submittals. *Construction documents* and supporting data shall be submitted in two or more sets with each application for a permit and in such form and detail as required by the County Engineer. The *construction documents* shall be prepared by a registered design professional where required by the statutes of Harris County in which the project is to be constructed.

Exception: The County Engineer is authorized to waive the submission of *construction documents* and supporting data not required to be prepared by a registered design professional if it is found that the nature of the work applied for is such that review of *construction documents* is not necessary to obtain compliance with this code.

105.4.1.1 Examination of documents. The County Engineer shall examine or cause to be examined the accompanying *construction documents* and shall ascertain by such examinations whether the work indicated and described is in accordance with the requirements of this code.

105.4.2 Information on construction documents. *Construction documents* shall be drawn to scale or dimensioned, and on suitable material. Electronic media documents are preferred. *Construction documents* shall be of sufficient clarity to indicate the location, nature and extent of the work proposed and show in detail that it will conform to the provisions of this code and relevant laws, ordinances, rules and regulations as determined by the *fire code official* and County Engineer.

105.4.2.1 Fire protection system shop drawings. Shop drawings for the fire protection system(s) shall be submitted to indicate compliance with this code and the *construction documents*, and shall be *approved* prior to the start of installation. Shop drawings shall contain all information as required by the referenced installation standards in Chapter 9.

105.4.3 Applicant responsibility. It shall be the responsibility of the applicant to ensure that the *construction documents* include all of the fire protection requirements and the shop drawings are complete and in compliance with the applicable codes and standards.

105.4.4 Approved documents. *Construction documents approved* by the County Engineer are *approved* with the intent that such *construction documents* comply in all respects with this code. Review and approval by the County Engineer shall not relieve the applicant of the responsibility of compliance with this code.

105.4.4.1 Phased approval. The County Engineer is authorized to issue a permit for the construction of part of a structure, system or operation before the *construction documents* for the whole structure, system or operation have been submitted, provided that adequate information and detailed statements have been filed complying with pertinent requirements of this code. The holder of such permit for parts of a structure, system or operation shall proceed at the holder's own risk with the building operation and without assurance that a permit for the entire structure, system or operation will be granted.

105.4.5 Amended construction documents. Work shall be installed in accordance with the *approved construction documents*, and any changes made during construction that are not in compliance with the *approved construction documents* shall be resubmitted for approval as an amended set of *construction documents*.

105.4.6 Retention of construction documents. One set of *construction documents* shall be retained by the County Engineer for a period of not less than 180 days from date of completion of the permitted work, or as required by state or local laws. One set of *approved construction documents* shall be

returned to the applicant and said set shall be kept on the site of the building or work at all times during which the work authorized thereby is in progress.

105.5 Revocation. The *fire code official* or County Engineer is authorized to revoke a permit issued under the provisions of this code where it is found by inspection or otherwise that there has been a false statement or misrepresentation as to the material facts in the application or *construction documents* on which the permit or approval was based including, but not limited to, any one of the following:

1. The permit is used for a location or establishment other than that for which it was issued.
2. The permit is used for a condition or activity other than that listed in the permit.
3. Conditions and limitations set forth in the permit have been violated.
4. There have been any false statements or misrepresentations as to the material fact in the application for permit or plans submitted or a condition of the permit.
5. The permit is used by a different person or firm than the name for which it was issued.
6. The permittee failed, refused or neglected to comply with orders or notices duly served in accordance with the provisions of this code within the time provided therein.
7. The permit was issued in error or in violation of an ordinance, regulation or this code.

105.6 Required operational permits. The *fire code official* is authorized to issue operational permits for the operations set forth in Sections 105.6.1 through 105.6.50. Each operation set forth requires a separate operational permit.

105.6.1 Aerosol products. An operational permit is required to manufacture, store or handle an aggregate quantity of Level 2 or Level 3 aerosol products in excess of 500 pounds (227 kg) net weight.

105.6.2 Amusement buildings. An operational permit is required to operate a special amusement building.

105.6.3 Aviation facilities. An operational permit is required to use a Group H or Group S occupancy for aircraft servicing or repair and aircraft fuel-servicing vehicles. Additional permits required by other sections of this code include, but are not limited to, hot work, hazardous materials and flammable or combustible finishes.

105.6.4 Carnivals and fairs. An operational permit is required to conduct a carnival or fair.

105.6.5 Cellulose nitrate film. An operational permit is required to store, handle or use cellulose nitrate film in a Group A occupancy.

105.6.6 Combustible dust-producing operations. An operational permit is required to operate a grain elevator, flour starch mill, feed mill, or a plant pulverizing aluminum, coal, cocoa, magnesium, spices or sugar, or other operations producing *combustible dusts* as defined in Chapter 2.

105.6.7 Combustible fibers. An operational permit is required for the storage and handling of *combustible fibers* in quantities greater than 100 cubic feet (2.8 m³).

Exception: A permit is not required for agricultural storage.

105.6.8 Compressed gases. An operational permit is required for the storage, use or handling at *normal temperature and pressure* (NTP) of *compressed gases* in excess of the amounts listed in Table 105.6.8.

Exception: Vehicles equipped for and using *compressed gas* as a fuel for propelling the vehicle.

TABLE 105.6.8**PERMIT AMOUNTS FOR COMPRESSED GASES**

Type of Gas	Amount (Cubic feet at NTP.)
Carbon dioxide used in carbon dioxide enrichment systems	875 (100 lbs.)
Carbon dioxide used in insulated liquid carbon dioxide beverage dispensing applications	875 (100 lbs.)
Corrosive	200
Flammable (except cryogenic fluids and liquefied petroleum gases)	200
Highly toxic	Any Amount
Inert and simple asphyxiant	6,000
Oxidizing (including oxygen)	504
Pyrophoric	Any Amount
Toxic	Any Amount

For SI: 1 cubic foot = 0.02832 m³.

105.6.9 Covered and open mall buildings. An operational permit is required for:

1. The placement of retail fixtures and displays, concession equipment, displays of highly combustible goods and similar items in the mall.
2. The display of liquid- or gas-fired equipment in the mall.
3. The use of open-flame or flame-producing equipment in the mall.

105.6.10 Cryogenic fluids. An operational permit is required to produce, store, transport on site, use, handle or dispense *cryogenic fluids* in excess of the amounts listed in Table 105.6.10.

Exception: Permits are not required for vehicles equipped for and using *cryogenic fluids* as a fuel for propelling the vehicle or for refrigerating the lading.

TABLE 105.6.10

PERMIT AMOUNTS FOR CRYOGENIC FLUIDS

Type of Cryogenic Fluid	Inside Building (gallons)	Outside Building (gallons)
Flammable	More than 1	60
Inert	60	500
Oxidizing (includes oxygen)	10	50
Physical or health hazard not indicated above	Any Amount	Any Amount

For SI: 1 gallon = 3.785 L.

105.6.11 Cutting and welding. An operational permit is required to conduct cutting or welding operations within the jurisdiction.

105.6.12 Dry cleaning. An operational permit is required to engage in the business of dry cleaning or to change to a more hazardous cleaning solvent used in existing dry cleaning equipment.

105.6.13 Exhibits and trade shows. An operational permit is required to operate exhibits and trade shows.

105.6.14 Explosives. An operational permit is required for the manufacture, storage, handling, sale or use of any quantity of *explosives, explosive materials*, fireworks or pyrotechnic special effects within the scope of Chapter 56.

Exception: Storage in Group R-3 occupancies of smokeless propellant, black powder and small arms primers for personal use, not for resale and in accordance with Section 5606.

105.6.15 Fire Brigades. An operational permit is required for facilities that have a fire brigade.

105.6.16 Fire hydrants and valves. Harris County does not regulate the use of hydrants, mains, or valves owned by a utility district. All permissions shall be obtained from the applicable utility district providing services.

105.6.17 Flammable and combustible liquids. An operational permit is required:

1. To use or operate a pipeline for the transportation within facilities of flammable or *combustible liquids*. This requirement shall not apply to the offsite transportation in pipelines regulated by the Department of Transportation (DOTn) nor does it apply to piping systems.
2. To store, handle or use Class I liquids in excess of 5 gallons (19 L) in a building or in excess of 10 gallons (37.9 L) outside of a building, except that a permit is not required for the following:
 - 2.1. The storage or use of Class I liquids in the fuel tank of a motor vehicle, aircraft, motorboat, mobile power plant or mobile heating plant, unless such storage, in the opinion of the *fire code official*, would cause an unsafe condition.
 - 2.2. The storage or use of paints, oils, varnishes or similar flammable mixtures where such liquids are stored for maintenance, painting or similar purposes for a period of not more than 30 days.

3. To store, handle or use Class II or Class IIIA liquids in excess of 25 gallons (95 L) in a building or in excess of 60 gallons (227 L) outside a building, except for fuel oil used in connection with oil burning equipment.

4. To store, handle or use Class IIIB liquids in tanks or portable tanks for fueling motor vehicles at motor fuel-dispensing facilities or where connected to fuel-burning equipment.

Exception: Fuel oil and used motor oil used for space heating or water heating.

5. To remove Class I or II liquids from an underground storage tank used for fueling motor vehicles by any means other than the *approved*, stationary on-site pumps normally used for dispensing purposes.

6. To operate tank vehicles, equipment, tanks, plants, terminals, wells, fuel-dispensing stations, refineries, distilleries and similar facilities where flammable and *combustible liquids* are produced, processed, transported, stored, dispensed or used.

7. To place temporarily out of service (for more than 90 days) an underground, protected above-ground or above-ground flammable or *combustible liquid* tank.

8. To change the type of contents stored in a flammable or *combustible liquid* tank to a material that poses a greater hazard than that for which the tank was designed and constructed.

9. To manufacture, process, blend or refine flammable or *combustible liquids*.

10. To engage in the dispensing of liquid fuels into the fuel tanks of motor vehicles at commercial, industrial, governmental or manufacturing establishments in accordance with Section 5706.5.4 or to engage in on-demand mobile fueling operations in accordance with Section 5707.

11. To utilize a site for the dispensing of liquid fuels from tank vehicles into the fuel tanks of motor vehicles, marine craft and other special equipment at commercial, industrial, governmental or manufacturing establishments in accordance with Section 5706.5.4 or, where required by the fire code official, to utilize a site for on-demand mobile fueling operations in accordance with Section 5707.

105.6.18 Floor finishing. An operational permit is required for floor finishing or surfacing operations exceeding 350 square feet (33 m²) using Class I or Class II liquids.

105.6.19 Fruit and crop ripening. An operational permit is required to operate a fruit- or crop-ripening facility or conduct a fruit-ripening process using ethylene gas.

105.6.20 Fumigation and insecticidal fogging. An operational permit is required to operate a business of fumigation or insecticidal fogging, and to maintain a room, vault or chamber in which a toxic or flammable fumigant is used.

105.6.21 Hazardous materials. An operational permit is required to store, transport on site, dispense, use or handle hazardous materials in excess of the amounts listed in Table 105.6.20.

TABLE 105.6.21**PERMIT AMOUNTS FOR HAZARDOUS MATERIALS**

Type of Material	Amount
Combustible Liquids	See Section 105.6.17
Corrosive Materials	
Gases	See Section 105.6.9
Liquids	
Solids	55 gallons 1000 pounds
Explosive Materials	See Section 105.6.15
Flammable Materials	
Gases	See Section 105.6.9
Liquids	
Solids	See Section 105.6.17 100 pounds
Highly Toxic Materials	
Gases	See Section 105.6.9
Liquids	
Solids	Any Amount Any Amount
Organic Peroxides	
Liquids	
Class I	Any Amount
Class II	Any Amount
Class III	1 gallon
Class IV	2 gallon
Class V	No Permit Required
Solids	
Class I	
Class II	Any Amount
Class III	Any Amount
Class IV	10 pounds

Class V	20 pounds No Permit Required
Oxidizing Materials	
Gases	See Section 105.6.9
Liquids	
Class 4	Any Amount
Class 3	1 gallon ^a
Class 2	10 gallons
Class 1	55 gallons
Solids	
Class 4	Any Amount
Class 3	10 pounds ^b
Class 2	100 pounds
Class 1	500 pounds
Pyrophoric Materials	
Gases	Any Amount
Liquids	Any Amount
Solids	Any Amount
Toxic Materials	
Gases	See Section 105.6.9
Liquids	10 gallons
Solids	100 pounds
Unstable (reactive) Materials	
Liquids	
Class 4	Any Amount
Class 3	Any Amount
Class 2	5 gallons
Class 1	10 gallons
Solids	
Class 4	Any Amount
Class 3	Any Amount

Class 2	50 pounds
Class 1	100 pounds
Water-reactive Materials	
Liquids	
Class 3	Any Amount
Class 2	5 gallons
Class 1	55 gallons
Solids	
Class 3	Any Amount
Class 2	50 pounds
Class 1	500 pounds

For SI: 1 gallon = 3.785 L, 1 pound = 0.454 kg.

- a. 20 gallons where Table 5003.1.1(1) Note k applies and hazard identification signs in accordance with Section 5003.5 are provided for quantities of 20 gallons or less.
- b. 200 pounds where Table 5003.1.1(1) Note k applies and hazard identification signs in accordance with Section 5003.5 are provided for quantities of 200 pounds or less.

105.6.22 HPM facilities. An operational permit is required to store, handle or use hazardous production materials.

105.6.23 High-piled storage. An operational permit is required to use a building or portion thereof with more than 500 square feet (46 m²), including aisles, of *high-piled storage*.

105.6.24 Hot work operations. An operational permit is required for hot work including, but not limited to:

1. Public exhibitions and demonstrations where hot work is conducted.
2. Use of portable hot work equipment inside a structure.
3. Fixed-site hot work equipment, such as welding booths.
4. Hot work conducted within a wildfire risk area.
5. Application of roof coverings with the use of an open-flame device.

6. Where *approved*, the *fire code official* shall issue a permit to carry out a hot work program. This program allows *approved* personnel to regulate their facility's hot work operations. The *approved* personnel shall be trained in the fire safety aspects denoted in this chapter and shall be responsible for issuing permits requiring compliance with the requirements found in Chapter 35. These permits shall be issued only to their employees or hot work operations under their supervision.

105.6.25 Industrial ovens. An operational permit is required for operation of industrial ovens regulated by Chapter 30.

105.6.26 Lumber yards and woodworking plants. An operational permit is required for the storage or processing of lumber exceeding 100,000 board feet (8,333 ft³) (236m³).

105.6.27 Liquid- or gas-fueled vehicles or equipment in assembly buildings. An operational permit is required to display, operate or demonstrate liquid- or gas-fueled vehicles or equipment in assembly buildings.

105.6.28 LP-gas. An operational permit is required for:

1. Storage and use of LP-gas.

Exception: A permit is not required for individual containers with a 500-gallon (1893 L) water capacity or less or multiple container systems having an aggregate quantity not exceeding 500 gallons (1893 L), serving occupancies in Group R-3.

2. Operation of cargo tankers that transport LP-gas.

105.6.29 Magnesium. An operational permit is required to melt, cast, heat treat or grind more than 10 pounds (4.54 kg) of magnesium.

105.6.30 Miscellaneous combustible storage. An operational permit is required to store in any building or on any premises in excess of 2,500 cubic feet (71 m³) gross volume of combustible empty packing cases, boxes, barrels or similar containers, combustible pallets, rubber tires, rubber, cork or similar combustible material.

105.6.31 Mobile food preparation vehicles. A permit is required for all mobile food units operating within Harris County.

105.6.32 Motor fuel-dispensing facilities. An operational permit is required for the operation of automotive, marine and fleet motor fuel-dispensing facilities.

105.6.33 Mobile Re-fueling. An operational permit is required for mobile re-fueling operations.

Exception: Mobile Re-fueling Operations conducted for the purpose of an emergency operation shall not require a permit.

105.6.34 Multiple tenant/Guestroom Housing. An operational permit is required to own or operate a multiple tenant or guestroom facility. This shall include but not be limited to lodging houses, alternative living facilities, flophouses, and halfway houses. This shall not include motels, hotels, bed and breakfast facilities, or apartments.

105.6.35 Open burning. Open burning is regulated by the Harris County Pollution Control Services Department (HCPCSD) and the Texas Commission on Environmental Quality (TCEQ). All permissions shall be obtained from these entities.

105.6.36 Open flames and torches. An operational permit is required to remove paint with a torch; or to use a torch or open-flame device in a wildfire risk area.

105.6.37 Open flames and candles. An operational permit is required to use open flames or candles in connection with assembly areas, dining areas of restaurants or drinking establishments.

105.6.38 Organic coatings. An operational permit is required for any organic-coating manufacturing operation producing more than 1 gallon (4 L) of an organic coating in one day.

105.6.39 Outdoor assembly venue. An operational permit is required to operate open land as a business for assemblies, recreational activities, or gatherings.

105.6.40 Places of assembly. An operational permit is required to operate a place of assembly. This permit requirement shall include but is not limited to any location that allows service and consumption of alcohol on premises regardless of the determined maximum occupant load.

105.6.1 Plant extraction systems. An operational permit is required to use plant extraction systems.

105.6.42 Private fire hydrants. An operational permit is required for the removal from service, use or operation of private fire hydrants.

Exception: A permit is not required for private industry with trained maintenance personnel, private fire brigade or fire departments to maintain, test and use private hydrants.

105.6.43 Pyrotechnic special effects material. An operational permit is required for use and handling of pyrotechnic special effects material.

105.6.44 Pyroxylin plastics. An operational permit is required for storage or handling of more than 25 pounds (11 kg) of cellulose nitrate (pyroxylin) plastics, and for the assembly or manufacture of articles involving pyroxylin plastics.

105.6.45 Refrigeration equipment. An operational permit is required to operate a mechanical refrigeration unit or system regulated by Chapter 6.

105.6.46 Repair garages and motor fuel-dispensing facilities. An operational permit is required for operation of repair garages.

105.6.47 Rooftop heliports. An operational permit is required for the operation of a rooftop heliport.

105.6.48 Spraying or dipping. An operational permit is required to conduct a spraying or dipping operation utilizing flammable or *combustible liquids*, or the application of combustible powders regulated by Chapter 24.

105.6.49 Storage of scrap tires and tire byproducts. An operational permit is required to establish, conduct or maintain storage of scrap tires and tire byproducts that exceeds 2,500 cubic feet (71 m³) of total volume of scrap tires, and for indoor storage of tires and tire byproducts.

105.6.-50 Temporary membrane structures and tents. An operational permit is required to operate an air-supported temporary membrane structure, a temporary *special event structure* or a tent having an area in excess of 400 square feet (37 m²).

Exceptions:

1. Tents used exclusively for recreational camping purposes.
2. Tents open on all sides, which comply with all of the following:
 - 2.1. Individual tents having a maximum size of 700 square feet (65 m²).
 - 2.2. The aggregate area of multiple tents placed side by side without a fire break clearance of not less than 12 feet (3658 mm) shall not exceed 700 square feet (65 m²) total.
 - 2.3. A minimum clearance of 12 feet (3658 mm) to structures and other tents shall be provided.

105.6.51 Temporary Outdoor Assembly Event. An operational permit is required to conduct a temporary *outdoor assembly event* where planned attendance exceeds 100 persons and is intended to operate for less than 180 days. All temporary event permits shall be valid for no more than 90 days. If event is intended to exceed 90 days, a new application will be required with inspection and approval to allow for additional days not to exceed a total of 180 days.

105.6.52 Tire-rebuilding plants. An operational permit is required for the operation and maintenance of a tire-rebuilding plant.

105.6.53 Waste handling. An operational permit is required for the operation of wrecking yards, junk yards and waste material-handling facilities.

105.6.54 Wood products. An operational permit is required to store chips, hogged material, lumber or plywood in excess of 200 cubic feet (6 m³).

105.7 Required construction permits. The building official is authorized to issue construction permits for work as set forth in Sections 105.7.1 through 105.7.18 and Chapters 2-10, 30, 35, and Sections 1405, 1505, 1705.14 through 1705.18, 2403, 2406 through 2409, 3101 through 3105, 3110, 3111, 3301, 3302, 3306, 3307, 3309 through 3314 and Appendix C of the *International Building Code*.

105.7.1 Automatic fire-extinguishing systems. A construction permit is required for installation of or modification to an automatic fire-extinguishing system. Maintenance performed in accordance with this code is not considered to be a modification and does not require a permit.

105.7.2 Battery systems. A construction permit is required to install stationary storage battery systems regulated by Section 1206.2.

105.7.3 Building Construction Permits. A construction permit is required to construct, substantially improve, enlarge, alter, repair, move, or change the occupancy of a building or structure, or to erect, install, enlarge, alter, repair, remove, convert, or replace the installation of which is regulated by this code, or to cause any such work to be performed.

105.7.4 Capacitor energy storage systems. A construction permit is required to install capacitor energy storage systems regulated by Section 1206.3.

105.7.5 Compressed gases. Where the compressed gases in use or storage exceed the amounts listed in Table 105.6.9, a construction permit is required to install, repair damage to, abandon, remove, place temporarily out of service, or close or substantially modify a *compressed gas* system.

Exceptions:

1. Routine maintenance.
2. For emergency repair work performed on an emergency basis, application for permit shall be made within two working days of commencement of work.

105.7.6 Cryogenic fluids. A construction permit is required for installation of or *alteration* to outdoor stationary *cryogenic fluid* storage systems where the system capacity exceeds the amounts listed in Table 105.6.10. Maintenance performed in accordance with this code is not considered to be an *alteration* and does not require a construction permit.

105.7.7 Emergency responder radio coverage system. A construction permit is required for installation of or modification to emergency responder radio coverage systems and related equipment. Maintenance performed in accordance with this code is not considered to be a modification and does not require a construction permit.

105.7.8 Fire alarm and detection systems and related equipment. A construction permit is required for installation of or modification to fire alarm and detection systems and related equipment. Maintenance performed in accordance with this code is not considered to be a modification and does not require a construction permit.

105.7.9 Fire pumps and related equipment. A construction permit is required for installation of or modification to fire pumps and related fuel tanks, jockey pumps, controllers and generators. Maintenance performed in accordance with this code is not considered to be a modification and does not require a construction permit.

105.7.10 Flammable and combustible liquids. A construction permit is required:

1. To install, repair or modify a pipeline for the transportation of flammable or *combustible liquids*.
2. To install, construct or alter tank vehicles, equipment, tanks, plants, terminals, wells, fuel-dispensing stations, refineries, distilleries and similar facilities where flammable and *combustible liquids* are produced, processed, transported, stored, dispensed or used.
3. To install, alter, remove, abandon or otherwise dispose of a flammable or *combustible liquid* tank.

105.7.11 Fuel cell power systems. A construction permit is required to install *stationary fuel cell power systems*.

105.7.12 Gas detection systems. A construction permit is required for the installation of or modification to gas detection systems. Maintenance performed in accordance with this code is not considered a modification and shall not require a permit.

105.7.13 Gates and barricades across fire apparatus access roads. A construction permit is required for the installation of or modification to a gate or barricade across a fire apparatus access road.

105.7.14 Hazardous materials. A construction permit is required to install, repair damage to, abandon, remove, place temporarily out of service, or close or substantially modify a storage facility or other area regulated by Chapter 50 where the hazardous materials in use or storage exceed the amounts listed in Table 105.6.20.

Exceptions:

1. Routine maintenance.
2. For repair work performed on an emergency basis, application for permit shall be made within two working days of commencement of work.

105.7.15 High-piled combustible storage. A construction permit is required for the installation of or modification to a structure exceeding 500 square feet (46 m²), including aisles, for high-piled combustible storage. Maintenance performed in accordance with this code is not considered to be a modification and does not require a construction permit.

105.7.16 Industrial ovens. A construction permit is required for installation of industrial ovens covered by Chapter 30.

Exceptions:

1. Routine maintenance.
2. For repair work performed on an emergency basis, application for permit shall be made within two working days of commencement of work.

105.7.17 LP-gas. A construction permit is required for installation of or modification to an LP-gas system. Maintenance performed in accordance with this code is not considered to be a modification and does not require a permit.

105.7.18 Motor vehicle repair rooms and booths. A construction permit is required to install or modify a motor vehicle repair room or booth. Maintenance performed in accordance with this code is not considered to be a modification and does not require a permit.

105.7.19 Plant extraction systems. A construction permit is required for installation of or modification to plant extraction systems. Maintenance performed in accordance with this code is not considered to be a modification and does not require a permit.

105.7.20 Private fire hydrants. A construction permit is required for the installation or modification of private fire hydrants. Maintenance performed in accordance with this code is not considered to be a modification and does not require a permit.

105.7.21 Smoke control or smoke exhaust systems. Construction permits are required for installation of or alteration to smoke control or smoke exhaust systems. Maintenance performed in accordance with this code is not considered to be an alteration and does not require a permit.

105.7.22 Solar photovoltaic power systems. A construction permit is required to install or modify solar photovoltaic power systems. Maintenance performed in accordance with this code is not considered to be a modification and does not require a permit.

105.7.23 Special event structure. A single construction permit is required to erect and take down a *temporary special event structure*.

105.7.24 Spraying or dipping. A construction permit is required to install or modify a spray room, dip tank or booth. Maintenance performed in accordance with this code is not considered to be a modification and does not require a permit.

105.7.25 Standpipe systems. A construction permit is required for the installation, modification or removal from service of a standpipe system. Maintenance performed in accordance with this code is not considered to be a modification and does not require a permit.

105.7.26 Temporary membrane structures and tents. A construction permit is required to erect an air-supported temporary membrane structure, a temporary stage canopy or a tent having an area in excess of 400 square feet (37 m²).

Exceptions:

1. Tents used exclusively for recreational camping purposes.
2. Funeral tents and curtains, or extensions attached thereto, when used for funeral services.
3. Tents and awnings open on all sides, which comply with all of the following:
 - 3.1. Individual tents shall have a maximum size of 700 square feet (65 m²).
 - 3.2. The aggregate area of multiple tents placed side by side without a fire break clearance of not less than 12 feet (3658 mm) shall not exceed 700 square feet (65 m²) total.

3.3. A minimum clearance of 12 feet (3658 mm) to structures and other tents shall be maintained.

SECTION 106

FEES

106.1 Fees. A permit shall not be issued until the fees have been paid, nor shall an amendment to a permit be released until the additional fee, if any, has been paid.

106.2 Schedule of permit fees. A fee for each permit shall be paid as required, in accordance with the schedule as established by Harris County Commissioners Court.

106.3 Work commencing before permit issuance. A person who commences any work, activity or operation regulated by this code before obtaining the necessary permits shall be subject to an additional fee established by the Harris County Commissioners Court, which shall be in addition to the required permit fees.

106.4 Related fees. The payment of the fee for the construction, *alteration*, removal or demolition of work done in connection to or concurrently with the work or activity authorized by a permit shall not relieve the applicant or holder of the permit from the payment of other fees that are prescribed by law.

106.5 Refunds. The Harris County Commissioners Court is authorized to establish a refund policy.

SECTION 107

INSPECTIONS

107.1 Inspection authority. The *fire code official* is authorized to enter and examine any building, structure, marine vessel, vehicle or premises in accordance with Section 104.3 for the purpose of enforcing this code.

107.2 Inspections. The *fire code official* is authorized to conduct such inspections as are deemed necessary to determine the extent of compliance with the provisions of this code and to approve reports of inspection by *approved* agencies or individuals. Reports of such inspections shall be prepared and submitted in writing for review and approval. Inspection reports shall be certified by a responsible officer of such *approved* agency or by the responsible individual. The *fire code official* is authorized to engage such expert opinion as deemed necessary to report on unusual, detailed or complex technical issues subject to the approval of the governing body.

107.2.1 Inspection requests. It shall be the duty of the holder of the permit or their duly authorized agent to notify the *fire code official* when work is ready for inspection. It shall be the duty of the permit holder to provide access to and means for inspections of such work that are required by this code.

107.2.2 Approval required. Work shall not be done beyond the point indicated in each successive inspection without first obtaining the approval of the *fire code official*. The *fire code official*, on notification, shall make the requested inspections and shall either indicate the portion of the construction that is satisfactory as completed, or notify the permit holder or his or her agent wherein the same fails to comply with this code. Any portions that do not comply shall be corrected, and such portion shall not be covered or concealed until authorized by the *fire code official*.

107.3 Concealed work. It shall be the duty of the permit applicant to cause the work to remain visible and able to be accessed for inspection purposes. Where any installation subject to inspection prior to use is covered or concealed without having first been inspected, the *fire code official* shall have the authority to require that such work be made visible and able to be accessed for inspection. Neither the *fire code official* nor Harris County shall be liable for expense entailed in the removal or replacement of any material required to allow inspection.

107.4 Approvals. Approval as the result of an inspection shall not be construed to be an approval of a violation of the provisions of this code or of other regulations or ordinances of Harris County. Inspections presuming to give authority to violate or cancel provisions of this code or of other regulation or ordinances of Harris County shall not be valid.

SECTION 108

MAINTENANCE

108.1 Maintenance of safeguards. Where any device, equipment, system, condition, arrangement, level of protection, or any other feature is required for compliance with the provisions of this code, or otherwise installed, such device, equipment, system, condition, arrangement, level of protection, or other feature shall thereafter be continuously maintained in accordance with this code and applicable referenced standards.

108.2 Testing and operation. Equipment requiring periodic testing or operation to ensure maintenance shall be tested or operated as specified in this code.

108.2.1 Re-inspection and testing. Where any work or installation does not pass an initial test or inspection, the necessary corrections shall be made so as to achieve compliance with this code. The work or installation shall then be resubmitted to the *fire code official* for inspection and testing.

108.3 Recordkeeping. A record of periodic inspections, tests, servicing and other operations and maintenance shall be maintained on the premises or other *approved* location for not less than 3 years, or a different period of time where specified in this code or referenced standards. Records shall be made available for inspection by the *fire code official*, and a copy of the records shall be provided to the *fire code official* on request. The *fire code official* is authorized to prescribe the form and format of such recordkeeping. The *fire code official* is authorized to require that certain required records be filed with the *fire code official*.

108.3.1 Reporting. Maintenance and testing shall be reported to the Fire Code Official through the Harris County Commissioner Court approved reporting platform. All installations, testing, maintenance, and yellow or red tag notifications shall be reported through this online platform, to the fire code official to be considered as the appropriate notification to the AHJ as ordered through the State mandated rules.

108.4 Supervision. Maintenance and testing shall be under the supervision of a responsible person who shall ensure that such maintenance and testing are conducted at specified intervals in accordance with this code.

108.5 Rendering equipment inoperable. Portable or fixed fire-extinguishing systems or devices, and fire-warning systems, shall be provided with ready access and shall not be rendered inoperative, except as necessary during emergencies, maintenance, repairs, *alterations*, drills or prescribed testing.

108.6 Overcrowding. Overcrowding or admittance of any person beyond the *approved* capacity of a building or a portion thereof shall not be allowed. The *fire code official*, on finding any overcrowding conditions or obstructions in *aisles*, passageways or other *means of egress*, or on finding any condition that constitutes a life safety hazard, shall be authorized to cause the event to be stopped until such condition or obstruction is corrected or require removal of occupants at a location when actual occupancy exceeds the permitted or posted occupant load. A person commits an offense if he refuses to obey an order to vacate.

SECTION 109

BOARD OF APPEALS

109.1 Board of appeals established. In order to hear and decide appeals of orders, decisions or determinations made by the *fire code official* or County Engineer relative to the application and interpretation of this code, there shall be and is hereby created a board of appeals. The board of appeals shall be appointed by Harris County Commissioner's Court and shall hold office at its pleasure. The *fire code official* and County Engineer shall be an ex officio member of said board but shall not have a vote on any matter before the board. The board shall adopt rules of procedure for conducting its business, and shall render all decisions and findings in writing to the appellant with a duplicate copy to the *fire code official* and County Engineer.

109.2 Limitations on authority. An application for appeal shall be based on a claim that the intent of this code or the rules legally adopted hereunder have been incorrectly interpreted, the provisions of this code do not fully apply, or an equivalent method of protection or safety is proposed. The board shall not have authority to waive requirements of this code.

109.3 Qualifications. The board of appeals shall consist of members who are qualified by experience and training to pass on matters pertaining to hazards of fire, explosions, hazardous conditions or *fire protection systems*, and are not employees of Harris County.

SECTION 110

VIOLATIONS

110.1 Unlawful acts. It shall be unlawful for a person, firm or corporation to erect, construct, alter, repair, remove, demolish or utilize a building, occupancy, premises or system regulated by this code, or cause same to be done, in conflict with or in violation of any of the provisions of this code. No work shall be commenced on any fire protection system at a new construction site or an existing structure, other than maintenance work, without a permit being issued or by approval to begin work by the Fire Code Official or County Engineer. Both the individual contractor, along with the site general contractor will be held liable for such actions. Where work is commenced prior to obtaining said permit, the fees may be increased as determined by the fee schedule adopted by Commissioners Court. Payment of the increased fee shall not relieve any person from fully complying with the requirements to obtain a permit nor of any other penalties herein.

110.2 Owner/occupant responsibility. Correction and abatement of violations of this code shall be the responsibility of the *owner* or the owner's authorized agent. Where an occupant creates, or allows to be created, hazardous conditions in violation of this code, the occupant shall be held responsible for the abatement of such hazardous conditions.

110.3 Notice of violation, Fire Marshal Order, or citation. Where the *fire code official* finds a building, premises, vehicle, storage facility or outdoor area that is in violation of this code, the *fire code official* is authorized to prepare a written notice of violation, Fire Marshal's order, or citation, describing the conditions deemed unsafe and, where compliance is not immediate, specifying a time for re-inspection or appearance in court.

110.3.1 Service. A notice of violation issued pursuant to this code shall be served on the *owner*, the owner's authorized agent, operator, occupant or other person responsible for the condition or violation, either by personal service, mail or by delivering the same to, and leaving it with, some person of responsibility on the premises. For unattended or abandoned locations, a copy of such notice of violation shall be posted on the premises in a conspicuous place at or near the entrance to such premises and the notice of violation shall be mailed by certified mail with return receipt requested or a certificate of mailing, to the last known address of the *owner*, the owner's authorized agent, or occupant.

110.3.2 Compliance with orders and notices. A notice of violation issued or served as provided by this code shall be complied with by the *owner*, the owner's authorized agent, operator, occupant or other person responsible for the condition or violation to which the notice of violation pertains. In cases of extreme danger to persons or property, immediate compliance is required. If the building or other premises is not owner occupied, under lease, or otherwise, and the order or notice requires additions or changes in the building or premises which would immediately become real estate and be the property of the owner of the building or premises, such orders or notices shall be complied with by the owner unless the owner and the occupant have agreed otherwise at which event the occupant shall comply.

110.3.3 Prosecution of violations. If the notice of violation is not complied with promptly, the *fire code official* is authorized to request the legal counsel of Harris County to institute the appropriate legal proceedings at law or in equity to restrain, correct or abate such violation or to require removal or termination of the unlawful occupancy of the structure in violation of the provisions of this code or of the order or direction made pursuant hereto.

110.3.4 Unauthorized tampering. Signs, tags or seals posted or affixed by the *fire code official* or County Engineer shall not be mutilated, destroyed or tampered with, or removed, without authorization from the issuer.

110.4 Violation penalties. Persons who shall violate a provision of this code or shall fail to comply with any of the requirements thereof or who shall erect, install, alter, repair or do work in violation of the *approved construction documents* or directive of the *fire code official*, or of a permit or certificate used under provisions of this code, shall be guilty of a misdemeanor, punishable by a fine of not more than \$500.00. Each day that a violation continues after due notice has been served shall be deemed a separate offense.

110.4.1 Abatement of violation. In addition to the imposition of the penalties herein described, the *fire code official* is authorized to institute appropriate action to prevent unlawful construction or to restrain, correct or abate a violation; or to prevent illegal occupancy of a structure or premises; or to stop an illegal act, conduct of business or occupancy of a structure on or about any premises.

110.4.2 Offense Penalties. Penalties for citations issued by the Fire Code Official or designee, are listed below, plus court cost,

Code	Section	Offense	Fine
Fire	104.11.4	Failure to remove debris or rubble after fire	\$200 to \$500
Fire	105.3.3	Occupancy prior to approval	\$200 to \$500
Fire	109.1	Working without permits (Plus Double Permit Fees)	\$200 to \$500
Fire	109.3.2 111.4	Failure to comply with orders and notices	\$200 to \$500
Fire	109.3.4	Unauthorized tampering or removal (tags, seal, sign, label, or posting)	\$100 to \$250
Fire	110.2.1	Unsafe building – overcrowding	\$500
Fire	503.4	Obstructing a Fire Lane	\$200 to \$500
Fire	1031.3	Obstructing Means of Egress	\$200 to \$500
Fire	108.3.1	Failure to report installation, testing, and maintenance of Fire Protection Systems	\$200 to \$500
Fire	All others	All other violations	\$200 to \$500

SECTION 111
UNSAFE BUILDINGS

111.1 General. If during the inspection of a premises, a building or structure, or any building system, in whole or in part, constitutes a clear and imminent threat to human life, safety or health, the *fire code official* shall issue such notice or orders to remove or remedy the conditions as shall be deemed necessary in accordance with this section, and shall refer the building to the County Engineer for any needed permits for repairs, *alterations*, remodeling, removing or demolition required. If the Fire Code Official determines that the identified hazardous conditions constitute an immediate threat to life or public harm, the fire code official is authorized to refer property owners or responsible parties to the Harris County Attorney's Office immediately for any and all available remedies.

111.1.1 Unsafe conditions. Structures or existing equipment that are or hereafter become unsafe or deficient because of inadequate *means of egress*, that constitute a fire hazard, are otherwise dangerous to human life or the public welfare, or involve illegal or improper occupancy or inadequate maintenance, shall be deemed an unsafe condition. A vacant structure that is not secured against unauthorized entry as required by Section 311 shall be deemed unsafe.

111.1.2 Structural hazards. Where an apparent structural hazard is caused by the faulty installation, operation or malfunction of any of the items or devices governed by this code, the *fire code official* shall immediately notify the building code official in accordance with Section 110.1.

111.2 Evacuation. The *fire code official* or the fire department official in charge of an incident shall be authorized to order the immediate evacuation of any occupied building deemed unsafe where such building has hazardous conditions that present imminent danger to building occupants. Persons so notified shall immediately leave the structure or premises and shall not enter or re-enter until authorized to do so by the *fire code official* or the fire department official in charge of the incident. Failure to comply with the orders of the fire code official or the in-charge officer of a fire scene shall constitute a violation of this code.

111.3 Summary abatement. Where conditions exist that are deemed hazardous to life and property, the *fire code official* or fire department official in charge of the incident is authorized to abate summarily such hazardous conditions that are in violation of this code.

111.4 Abatement. The *owner*, the owner's authorized agent, operator or occupant of a building or premises deemed unsafe by the *fire code official* shall abate or cause to be abated or corrected such unsafe conditions either by repair, rehabilitation, demolition or other *approved* corrective action.

SECTION 112

STOP WORK ORDER

112.1 Order. Where the *fire code official* finds any work regulated by this code being performed in a manner contrary to the provisions of this code, or in a dangerous or unsafe manner, the *fire code official* is authorized to issue a stop work order.

112.2 Issuance. A stop work order shall be in writing and shall be given to the *owner* of the property, or to the *owner's* authorized agent, or to the person doing the work. Upon issuance of a stop work order, the cited work shall immediately cease. The stop work order shall state the reason for the order, and the conditions under which the cited work is authorized to resume.

112.3 Emergencies. Where an emergency exists, the *fire code official* shall not be required to give a written notice prior to stopping the work.

112.4 Failure to comply. Any person who shall continue any work after having been served with a stop work order, except such work as that person is directed to perform to remove a violation or unsafe condition, shall be liable to a fine of not less than \$200.00 dollars or more than \$500.00 dollars.

SECTION 113

SERVICE UTILITIES

113.1 Authority to disconnect service utilities. The *fire code official* shall have the authority to authorize disconnection of utility service to the building, structure or system in order to safely execute emergency operations or to eliminate an immediate hazard. The *fire code official* shall notify the serving utility and, where possible, the *owner* or the owner's authorized agent and the occupant of the building, structure or service system of the decision to disconnect prior to taking such action. If not notified prior to disconnection, then the *owner*, the owner's authorized agent or occupant of the building, structure or service system shall be notified in writing as soon as practical thereafter.

EXHIBIT A

ADDITIONS, INSERTIONS, DELETION AND CHANGES TO

INTERNATIONAL FIRE CODE

2018 EDITION

CHAPTER 1

SCOPE AND ADMINISTRATION

CHAPTER 1 is deleted in its entirety and is replaced by Chapter 1-of the Harris County Fire Code as adopted by Harris County, Texas and to which this Exhibit is attached is substituted in its place. Notwithstanding any other provision of the Harris County Fire Code which might otherwise be interpreted to the contrary, the Harris County Fire Code shall not be construed as requiring any license or permit not specifically required by Chapter 1 unless required by other applicable law.

CHAPTER 2
DEFINITIONS

SECTION 202 is amended to include the following revised or additional definitions:

24-HOUR CARE. The actual time that a person is an occupant within a facility for the purpose of receiving care. It shall not include a facility that is open for 24 hours and is capable of providing care to someone visiting the facility during any segment of the 24 hours. See definitions for Group I occupancies as adopted by Harris County.

ADULT DAY CARE FACILITY. See Institutional ~~1-2~~ 1-4 occupancy definition.

ALTERNATE HOUSING FACILITY. A residence in which three or more unrelated parolees reside that is owned by an individual, private entity, a non-profit or faith-based organization, but is not operated by, established by, or contracted with the Texas Department of Criminal Justice.

AMBULATORY CARE FACILITY. Buildings or portions thereof used to provide medical, surgical, psychiatric, nursing or similar care on a less-than-24-hour basis to persons who are rendered incapable of self-preservation by the services provided or staff has accepted responsibility for care recipients already incapable. This group may include but not be limited to the following:

Dialysis centers

Sedation dentistry

Surgery centers

Colonic centers

Psychiatric centers

APPROVED. Acceptable to the fire code official and/or building official.

APPROVED CAPACITY. The maximum approved amount or number of gallons that can be received or contained; cubic contents; volume in cubic ft., or in gallons.

ASSISTED LIVING FACILITY. An establishment that furnishes in one or more facilities, food and shelter to four or more persons who are unrelated to the proprietor of the establishment and provides personal care services or administration of medication by a licensed person, or may provide limited skilled nursing services as outlined in the Texas Health and Safety Code chapter 247.

BOARDING HOME. A facility that furnishes, in one or more buildings, lodging to three or more persons with disabilities or elderly persons who are unrelated to the owner of the establishment by blood or marriage and provides community meals, light housework, meal preparation, transportation, grocery shopping, money management, laundry services, or assistance with self-administration of medications but does not provide personal care services.

BUILDING OFFICIAL. The County Building Official is an individual designated by the County Engineer who is the officer or other designated authority charged with the administration of the Harris County Fire Code, or a duly authorized representative.

CHILD DAY CARE FACILITY. Buildings and structures or portions thereof occupied by more than five children older than 2 ½ years of age for educational, supervision, or personal care services for less than 24 hours are considered an "E" occupancy. If the facility is operated and occupied for the purpose of 24-hour care, it shall be considered an "I" occupancy.

CRITICAL FACILITIES. Those facilities essential to the preservation of life and property, including, but not limited to: schools, nursing homes, hospitals, police, fire and emergency response installations, facilities used for the storage of critical records, and commercial installations which produce, use or store hazardous materials or hazardous waste (Group H occupancies).

DEDICATED FUNCTION FIRE ALARM CONTROL UNIT. A protected premises fire alarm control unit intended to provide operation of a specifically identified fire safety function, such as a fire sprinkler alarm and supervisory control unit or an elevator recall control and supervisory control unit.

FIRE ALARM CONTROL PANEL REPLACEMENT AND MAINTENANCE. Any maintenance to an existing fire alarm control panel that involves replacement or upgrade that requires a new installation tag and certification shall be considered a new system and shall meet the requirements of Section 907.2

FIRE CODE OFFICIAL. The fire code official shall be the person appointed by Commissioners Court as the County Fire Marshal or the employee(s) designated by the County Fire Marshal to perform a task required by this code. The Fire Marshal shall have enforcement authority for this code and shall conduct all required inspections for compliance with this code.

FIRE BRIGADE. A fire brigade shall be a certified assembly that meets the Occupational Safety and Health Standard (OSHA) 1910 and receive an operational permit.

FOSTER GROUP HOME. A child-care facility that provides care for 7 to 12 children for 24 hours a day.

FOSTER HOME. A child-care facility that provides care for not more than six children for 24 hours a day.

GENERAL RESIDENTIAL OPERATION. A child-care facility that provides care for more than 12 children for 24 hours a day, including facilities known as children's homes, halfway houses, residential treatment centers, emergency shelters, and therapeutic camps.

GROUP HOME. A residential board and care facility with at least four and no more than sixteen clients for social rehabilitation, substance abuse or mental health problems containing a group housing arrangement that provides custodial care but does not provide acute care.

MID-RISE BUILDING. A building with an occupied floor located more than 2 stories and less than 75 feet (22 860 mm) above the lowest level of fire department vehicle access.

MOBILE FOOD VEHICLE. Vehicles which are used for the sale of consumable items.

ASSEMBLY GROUP A-3. Assembly uses intended for worship, recreation or amusement and other assembly uses not classified elsewhere in Group A, including, but not limited to:

Amusement arcades

Art galleries

Bowling alleys

Community halls

Courtrooms

Dance halls (not including food or drink

consumption)

Exhibition halls

Funeral parlors

Gymnasiums (without spectator seating)
Indoor swimming pools (without spectator seating)
Indoor tennis courts (without spectator seating)
Lecture halls
Libraries
Martial Arts/Dance Studios/Fitness
Museums
Places of religious worship
Pool and billiard parlors
Waiting areas in transportation terminals

INSTITUTIONAL GROUP I-1. Institutional Group I-1 occupancy shall include buildings, structures or portions thereof for more than 16 persons, excluding staff, who reside on a 24-hour basis in a supervised environment and receive custodial care. Buildings of Group I-1 shall be classified as one of the occupancy conditions indicated below. This group shall include, but not be limited to, the following:

Alcohol and drug centers
Assisted living facilities
Congregate care facilities
Convalescent facilities
Group homes
General residential operation
Halfway houses
Residential Board and Care – Large A
Social rehabilitation facilities

Condition 1. This occupancy condition shall include buildings in which all persons receiving custodial care who, without any assistance, are capable of responding to an emergency situation to complete building evacuation.

Condition 2. This occupancy condition shall include buildings in which there are any persons receiving custodial care who require limited verbal or physical assistance while responding to an emergency situation to complete building evacuation.

Four to sixteen persons receiving care. A facility such as the above, housing at least four and not more than sixteen persons receiving such care, shall be classified as a Residential Board and Care - Small.

INSTITUTIONAL GROUP I-2. Institutional Group I-2 occupancy shall include buildings and structures used for medical care on a 24-hour basis for more than five persons who are not capable of self-preservation,

and not otherwise classified as a Residential Board and Care - Small, This group shall include, but not be limited to, the following:

Foster care facilities

Detoxification facilities

Hospitals

Nursing homes

Psychiatric hospital

Child and Adult day care facilities (in operation for more than 24 hours)

Residential Board and Care – Large B

Condition 1. This occupancy condition shall include facilities that provide nursing and medical care but do not provide emergency care, surgery, obstetrics, or in-patient stabilization units for psychiatric or detoxification, including, but not limited to, nursing homes and foster care facilities.

Condition 2. This occupancy condition shall include facilities that provide nursing and medical care and could provide emergency care, surgery, obstetrics, or inpatient stabilization units for psychiatric or detoxification, including, but not limited to, hospitals.

Four to sixteen persons receiving care. A facility such as the above, housing at least four and not more than sixteen persons receiving such care, shall be classified as a Residential Board and Care - Small.

LODGING HOUSE. A one-family dwelling that furnishes lodging, for payment, to three or more persons who are unrelated to the owner of the establishment by blood or marriage and one or more of the occupants are primarily permanent in nature. The term lodging house shall include the following; Emergency Shelters, Halfway Houses, Flophouses, and Alternative Living Facilities, however, the term shall not include a boarding homes, hotels, motels, bed and breakfast facilities, or a single-family residential building, condominium, or townhouse that is owner-occupied for at least three months of the year.

PERSONAL CARE SERVICES. Assistance with feeding, dressing, moving, bathing, or other personal needs or maintenance, or general supervision or oversight of the physical and mental well-being of a person who needs assistance to maintain a private and independent residence in an assisted living facility or who needs assistance to manage the person's personal life, regardless of whether a guardian has been appointed for the person.

PREMISES. A building together with its land and outbuildings, or open land occupied by a business or open for public use regardless of the connection with a business.

RESIDENTIAL BOARD AND CARE OCCUPANCY. An existing single-family residential occupancy, converted to be used for lodging and boarding of at least four but not more than 16 residents, not related by blood or marriage to the directors, owners or operators, for the purpose of providing personal care services. A Residential Board and Care Occupancy includes, but is not limited to:

Alcohol and drug centers

Assisted living facilities

Congregate care facilities
Convalescent facilities
Detoxification facilities
Foster family homes
Group homes
Hospices
Limited care facilities
Personal care facilities
Residential AIDS hospices
Residential treatment home
Social rehabilitation facilities
Special residential care facility

For the purposes of this Code, a facility such as the above in a residential setting, housing at least four and **not more than 16 persons** shall be classified as a Commercial Establishment: **Residential Board and Care, Small** and shall comply with the provisions of the current State adopted editions of Section 20.5 of the Uniform Fire Code, NFPA 1 Chapter 33 of NFPA 101 Life Safety Code, or applicable State and Federal requirements. If there is a conflict between the provisions of this section and the State or Federal requirements, rules, and regulations, the more stringent of the provisions shall apply.

For the purposes of this Code, a facility such as the above, housing **more than 16 persons** shall be classified as a Commercial Establishment: **Residential Board and Care, Large** and shall comply with the provisions of the current edition of the Harris County Fire Code, or applicable State and Federal requirements. If there is a conflict between the provisions of this section and the State or Federal requirements, rules, and regulations, the more stringent of the provisions shall apply.

Please refer to Exhibit B, Section 428 of the Harris County Fire Code for additional information and Residential Board and Care design criteria.

RESIDENTIAL GROUP R-3. Residential Group R-3 occupancies where the occupants are primarily permanent in nature and not classified as Group R-1, R-2, ~~R-4~~ or I, including:

Buildings that do not contain more than two *dwelling units*
Community Homes in compliance with Human Resource Code Chapter 123
Congregate living facilities (non-transient) with 16 or fewer occupants
Convents
Dormitories
Fraternities and sororities
Monasteries

Newly Constructed and/or Substantial Improved Boarding and Lodging houses shall comply with the Harris County Fire Code.

Conversion of an existing single-family dwelling into a Boarding or Lodging house.

Lodging houses (transient) with five or fewer *guestrooms* and 10 or fewer occupants shall be classified as a *single-family dwelling* for the purpose of this code and comply with **all** of the following:

1. The structure was originally constructed as a single-family dwelling.
2. The structure has an appraised real property record with Harris County Appraisal District for the past 2 years as a Residential, Single-Family use.
3. The structure is being converted into a Lodging House.
4. The structure is in compliance with Local Government Code 233 Subchapter F “Residential Building Code” or other recognized code.
5. The structure is in compliance with Chapter 11 of the Harris County Fire Code.
6. The structure is in compliance with all deed restrictions.
7. Subjected to the Building and/or Fire Code Official for approval.

Structures not complying with all items listed or determined by the Building and/or Fire Code Official not approvable shall be classified as new construction or substantial improvement per the Harris County Fire Code.

Boarding Houses in compliance with Chapter 260 of the Health & Safety Code shall be classified as a *single-family dwelling* for the purpose of this code and comply with **all** of the following:

1. The structure was originally constructed as a single-family dwelling.
2. The structure has an appraised real property record with Harris County Appraisal District for the past 2 years as a Residential, Single-Family use.
3. The structure is being converted into a Boarding Home.
4. The structure is in compliance with Local Government Code 233 Subchapter F “Residential Building Code” or other recognized code.
5. The structure is in compliance with Chapter 11 of the Harris County Fire Code.
6. The structure is in compliance with all deed restrictions.
7. The occupancy load shall not be less than 200 square feet per person.
8. The occupancy load shall not be greater than 16 for all occupants living within the dwelling.
9. Subjected to the Building and/or Fire Code Official for approval.

Structures not complying with all items listed or determined by the Building and/or Fire Code Official not approvable shall be classified as new construction or substantial improvement per the Harris County Fire Code.

RESIDENTIAL GROUP R-4. Omitted. Refer to Residential Board and Care.

READILY ACCESSIBLE. Accessible without any special tools, key, knowledge, or equipment to operate.

SINGLE-FAMILY DWELLING. Single family residential shall mean the use of a lot with one building designed for and containing not more than two separate units with facilities for living, sleeping, cooking, and eating therein. A lot upon which is located a free-standing building containing one dwelling unit and a detached secondary dwelling unit of not more than 900 square feet also shall be considered single family residential. A building that contains one dwelling unit on one lot that is connected by a party wall to another building containing one dwelling unit on an adjacent lot shall be single family residential.

SPECIAL EVENT. Any organized, temporary event with an estimated number of participants and spectators of 100 or more people set up outdoors in a parking lot, side of the roadway, open land, or involves using a building for an assembly of 50 or more people in a building not equipped or intended to be utilized for this purpose.

START OF CONSTRUCTION. Construction begins on the date that ground is broken for a building, or if no ground is broken, on the date that:

1. The first materials are added to the original property;
2. Foundation pilings are installed on the original property;
3. A manufactured building or relocated structure is placed on a foundation on the original property.

STRUCTURE. Something built or constructed to support or shelter any occupancy.

SUBSTANTIAL IMPROVEMENT. A "Substantial Improvement" is

- a) the repair, restoration, reconstruction, improvement, or remodeling of a public building, a commercial establishment, or a multifamily residential dwelling consisting of four or more units for which the cost exceeds 50% of the building's value according to the certified tax appraisal roll for the county for the year preceding the year in which the work was begun; or
- b) a change in occupancy classification involving a change in the purpose or level of activity in a building, including the renovation of a warehouse into a loft apartment. For purposes of determining if an improvement is a Substantial Improvement, the applicant for a permit must submit data reflecting cost of the improvement, restoration, reconstruction, improvement, or remodeling. Costs shall include the value of all labor and materials. A permit is required prior to the start of any Substantial Improvement. For purposes of this Code, Substantial Improvement begins on the date that the repair, restoration, reconstruction, improvement, or remodeling or the change in occupancy classification begins or on the date materials are first delivered for that purpose.

TEMPORARY. Any construction of a building or structure, tent or membrane structures, or any planned event which will be in operation for no more than 180 days.

UNINCORPORATED AREA. Unincorporated Area means the area in Harris County, Texas, which is not within an incorporated area of a city, town, and village or within 2,500 feet of the centerline of the Houston Ship Channel.

CHAPTER 3

GENERAL REQUIREMENTS

SECTION 319 – Section 319.1 is amended to read as follows; Sections 319.1.1, 319.11 and 319.2 are added to read as follows:

319.1 General. All vehicles shall comply with this section.

319.1.1 Location. A mobile food vehicle being used on a property shall comply with the following:

1. The vehicle shall not be parked beneath or within 20 feet of a structure while operating.
2. Accessory weather protection cannot exceed 700 square feet and shall be open on at least three sides.

319.11 Electrical. All electrical components shall be in compliance with Sections 604.1 through 604.9 and the National Electrical Code current edition (NFPA 70).

319.12 Solid Fuel Cooking. All solid fueled cooking appliances and operations shall be in accordance with NFPA 96, current addition.

CHAPTER 4

EMERGENCY PREPAREDNESS REQUIREMENTS

Section 403.12.3.1 is amended to read as follows:

403.12.3.1 Number of crowd managers. Not fewer than two trained crowd managers, and not less than one trained crowd manager for each 250 persons or portion thereof, shall be provided for the gathering.

Exceptions:

1. Outdoor events with fewer than 500 persons in attendance shall not require crowd managers.
2. Assembly occupancies used exclusively for religious worship with an occupant load not exceeding 1,000 shall not require crowd managers.
3. The number of crowd managers shall be reduced where, in the opinion of the fire code official, the fire protection provided by the facility and the nature of the event warrant a reduction.

CHAPTER 5

FIRE SERVICE FEATURES

SECTION 503.1.1 and Exceptions 1.1 and 1.2 are amended to read as follows:

503.1.1 Buildings and facilities. Approved fire apparatus access roads shall be provided for every facility, premises, building or portion of a building hereafter constructed or moved into or within the jurisdiction. The fire apparatus access road shall comply with the requirements of this section and Appendix D of this code. Fire apparatus access roads shall extend to within 150 feet (45 720 mm) of all portions of the facility and all portions of the exterior walls of the first story of the building as measured by an approved route around the exterior of the building or facility.

Exception 1.1. Buildings equipped throughout with an approved automatic sprinkler system installed in accordance with Section 903.3.1.1, 903.3.1.2 or 903.3.1.3, the dimension shall be increased to 200 feet.

Exception 1.2. When fire apparatus access roads cannot be installed because of location on property, topography, waterways, nonnegotiable grades or other similar conditions, and an approved alternative means of fire protection is provided. The use of remote fire hose connections in accordance with Section 918 may be considered as an alternative means of fire protection.

Section 503.2.1 is amended to read as follows:

503.2.1 Dimensions. Fire apparatus access roads shall have an unobstructed width of not less than 20 feet (6096 mm), exclusive of shoulders, except for *approved* security gates in accordance with Section 503.6, and an unobstructed vertical clearance of not less than 13 feet 6 inches (4115 mm). See Appendix D for additional requirements.

SECTION 503.3 is amended to read as follows:

503.3 Marking. Fire apparatus access roads shall be marked by painted lines of red traffic paint 6 in. width to show the boundaries of the lane. The words "NO PARKING FIRE LANE" or "FIRE LANE NO PARKING" shall appear in 4 in. white letters at 25 ft. intervals on the red border markings along both sides of the fire lanes. Where a curb is available, the striping shall be on both the vertical and horizontal faces of the curb.

When using signs to identify fire lanes, signs shall read "NO PARKING FIRE LANE" or "FIRE LANE NO PARKING" and shall be 12 in. wide and 18 in. Signs shall be painted on a white background with letters and borders in red, using not less than 2 in. lettering. Signs shall be permanently affixed to a stationary post and the bottom of the sign shall be 6'- 6" in. above finished grade. Signs shall be spaced not more than 50 ft. apart. Signs may be installed on permanent buildings or walls or as approved by the Fire Marshal. The means by which *fire lanes* are designated shall be maintained in a clean and legible condition at all times and be replaced or repaired when necessary to provide adequate visibility.

SECTION 505 – Section 505.1 is amended to read as follows; **Section 505.1.1** is added to read as follows:

505.1 Address identification. New and existing buildings shall be provided with approved address identification. The address identification shall be legible and placed in a position that is clearly identifiable and visible from the street or road fronting the property. Address identification characters shall contrast with their background. Address numbers shall be Arabic numbers or alphabetical letters. Numbers shall not be spelled out. Each character shall be not less than 4 inches (102 mm) high with a minimum stroke width of 1/2 inch (12.7 mm). Where required by the fire code official, address identification shall be provided in additional approved locations to facilitate emergency response. Where access is by means of a private road and the building cannot be viewed from the public way, a monument, pole or other sign or

means shall be used to identify the structure. Address identification shall be maintained.

505.1.1 Additional Identification Required. In multi-tenant buildings where exterior exit doors face directions other than front of building, each door shall be labeled with business name and suite number or address. Numbers and letters shall be Arabic numbers or alphabetical block letters, not less than 2 ½ inches in height and a minimum stroke width of ¼ inch.

SECTION 506.1.1 is amended to read as follows:

506.1.1 Locks. An approved lock shall be installed on gates, doors or similar barriers where required by the fire code official. Only key locks, key boxes, and key box systems manufactured and supplied by the Knox® Company, with a key cut for unincorporated Harris County shall be utilized.

SECTION 506.1.2 Item 3 is amended to read as follows:

1. The key box shall be mounted within 20 feet of the main elevator bank at the lobby nearest to the lowest level of fire department access.

SECTION 506.1.3 is added to read as follows:

506.1.3 Gated Communities and Multi-Unit Housing. To assure reasonable access for fire-fighting vehicles and equipment, emergency medical services vehicles, and law enforcement officers, the owner or the owners association of a gated community or multi-unit housing project shall comply with this section.

506.1.3.1 Vehicular Gates. Each vehicular gate to the gated community or multi-unit housing project must have a key box within sight of the gate and in close proximity outside the gate or a chain with approved lock. The key box at all times must contain a key, card, or code to open the gate or a key switch or cable mechanism that overrides the key, card, or code that normally opens the gate and allows the gate to be opened manually.

506.1.3.2 Pedestrian Gates. If there are one or more pedestrian gates, at least one pedestrian gate must have a key box within sight of the gate and in close proximity outside the gate. The key box at all times must contain a key, card, code, key switch, or cable mechanism to open the gate. If different pedestrian gates are operated by different keys, cards, or codes, the key box must contain:

1. Each key, card, or code, properly labeled for its respective gate; or
2. A single master key, card, code, or a key switch or cable mechanism that will open every gate.

506.1.3.3 Electrical Power Gate. If a gate is powered by electricity, it must be possible to open the gate without a key, card, code, or key switch if the gate loses electrical power.

SECTIONS 506.3 and 506.4 are added to read as follows:

506.3 Approved Markings. Key boxes shall have the door to the box painted bright red so as to be readily noticeable with wording "FIRE DEPT" in white permanent letters not less than 1 inch in height.

506.4 Key Box Access. Access to a key box required by this section shall be limited to a person or agency providing fire-fighting or emergency medical services for the county.

Section 509.2.1 is added to read as follows:

509.2.1 Locking/Securing. All rooms, suites, buildings, or occupancies which contain fire protection

equipment shall be provided with a lock box for fire department access. Only key boxes and key box systems manufactured and supplied by the Knox® Company, with a key cut for unincorporated Harris County shall be utilized.

SECTION 510 is amended to read as follows:

SECTION 510 – 2018 IFC

EMERGENCY RESPONDER RADIO COVERAGE

510.1 Emergency responder radio coverage in new buildings. New buildings shall have approved radio coverage for emergency responders within the building based on the existing coverage levels of the public safety communication systems utilized by the jurisdiction, measured at the exterior of the building. Frequencies will be outline by contacting Harris County Universal Services radio shop, and the responding jurisdiction. Coverage shall include the Harris County Radio System (TxWARN). The frequency range to be supported is 700-800 MHz (FDMA and TDMA)). Additional VHF/UHF (150-174 MHz/408-512 MHz) frequency range may be required based upon the need of local public safety services or as otherwise required in writing by Harris County for public safety purposes. Any building or structure that fails to support adequate radio coverage must be brought into compliance. The owner shall immediately contact the Harris County Fire Marshal’s Office to report the system failure. This section shall not require improvement of the existing public safety communication systems.

Exceptions:

1. Where it is determined by the fire code official that the radio coverage system is not needed.
2. Buildings less than 50,000 square feet.
3. Single-family detached residential dwellings and multifamily buildings.
4. Any building less than four stories in height with less than 50,000 square feet per floor.

510.2 Emergency responder radio coverage in existing buildings. Existing buildings shall be provided with approved radio coverage for emergency responders as required in Chapter 11.

510.3 Permit required. A construction permit for the installation of or modification to emergency responder radio coverage systems and related equipment is required as specified in Section 105.7.6. Maintenance performed in accordance with this code is not considered a modification and does not require a permit. Permit application must include:

- A) Submittal Document: This document must include the material list, data sheets of the materials, snapshots of the overall design plan and floor plans.
- B) Overall design plan, Floor plans with the design, prediction propagation heat maps on PDF format with proper labeling for each component on a 24”x36” scale. Design plan will also include projected emission limits to reduce the interference potential that would cause adverse effects of increased noise floor at the donor site.
- C) Benchmark test is required for each floor to make sure the amount of coverage is needed (whole floor, partial floor or none needed). The results of this test must include the make/model and calibration certificate of the measurement device used.

510.4 Technical requirements. Systems, components and equipment required to provide the emergency responder radio coverage system shall comply with Sections 510.4.1 through 510.4.2.8.

510.4.1 Emergency responder communication enhancement system signal strength. The building shall be considered to have acceptable emergency responder communications enhancement system coverage when signal strength measurements in 95 percent of all areas and 99% in critical use areas on each floor of the building meet the signal strength requirements in Sections 510.4.1.1 through 510.4.1.3. Critical areas are defined as fire command center(s), fire pump room(s), exit stairs, exit passageways, elevator lobbies, standpipe cabinets, sprinkler sectional valve locations, and other areas deemed critical.

510.4.1.1 Minimum signal strength into the building. The minimum inbound signal strength shall be sufficient to provide usable voice communications throughout the coverage area as specified by the fire code official. The inbound signal level shall be sufficient to provide not less than -95 dBm for analog systems or a Delivered Audio Quality (DAQ) of 3.0 for digital systems or an equivalent Signal-to-Interference-Plus-Noise-Ratio (SINR) applicable to the technology for either analog or digital signals.

510.4.1.2 Minimum signal strength out of the building. The minimum outbound signal strength shall be sufficient to provide usable voice communications throughout the coverage area as specified by the fire code official. The outbound signal level shall be sufficient to provide not less than -95 dBm for analog systems or a DAQ 3.0 for digital systems or an equivalent Signal-to-Interference-Plus-Noise-Ratio (SINR) applicable to the technology for either analog or digital signals.

510.4.1.3 System performance. Signal strength shall be sufficient to meet the requirements of the applications being utilized by public safety for emergency operations through the coverage area as specified by the fire code official in Section 510.4.2.2.

510.4.2 System design. The emergency responder radio coverage system shall be designed in accordance with Sections 510.4.2.1 through 510.4.2.5.

510.4.2.1 Amplification systems and components. Buildings and structures that cannot support the required level of radio coverage shall be equipped with any of the following in order to achieve adequate radio coverage:

1. A radiating cable system.
2. An internal multiple system with FCC Type Accepted Bi-Directional Amplifiers as required to encompass the frequency ranges as specified in Section 510.1, or as subsequently established by Harris County.

Donor antennas must be optimized for directional reception from a single transmitter site.

510.4.2.2 Technical criteria. Harris County Universal Services shall maintain or provide to the fire code official a document providing the specific technical information and requirements for the emergency responder communications coverage system. This document shall contain, but not be limited to, the various frequencies required, the location of radio sites, the effective radiated power of radio sites, the maximum propagation delay in microseconds, the applications being used and other supporting technical information necessary for system design.

510.4.2.3 Standby power. Emergency responder radio coverage systems shall be provided with dedicated standby batteries or provided with 2-hour standby batteries and connected to the facility generator power system in accordance with Section 1203. The standby power supply shall be capable of operating the emergency responder radio coverage system at 100-percent system capacity for a duration of not less

than 12 hours.

510.4.2.4 Signal booster requirements. If used, signal boosters shall meet the following requirements:

1. All signal booster components shall be contained in a National Electrical Manufacturer's Association (NEMA) 4-type waterproof cabinet.
2. Battery systems used for the emergency power source shall be contained in a NEMA 3R or higher rated cabinet.
3. Equipment shall have FCC or other radio licensing authority and be suitable for public safety use prior to installation.
4. Where a donor antenna exists, isolation shall be maintained between the donor antenna and all inside antennas to not less than 20dB greater than the system gain under all operating conditions.
5. Bi-Directional Amplifiers (BDA's) used in emergency responder radio coverage systems shall have oscillation prevention circuitry.
6. The installation of amplification systems or systems that operate on or provide the means to cause interference on any emergency responder radio coverage networks shall be coordinated and approved by the fire code official.

510.4.2.5 System monitoring. The emergency responder radio enhancement system shall be monitored by a listed fire alarm control unit, or where approved by the fire code official, shall sound an audible signal at a constantly attended on-site location. Automatic supervisory signals shall include the following:

1. Loss of normal AC power supply.
2. System battery charger(s) failure.
3. Malfunction of the donor antenna(s).
4. Failure of active RF-emitting device(s).
5. Low-battery capacity at 70-percent reduction of operating capacity.
6. Failure of critical system components.
7. The communications link between the fire alarm system and the emergency responder radio enhancement system.

510.4.2.6 Additional frequencies and change of frequencies. The emergency responder radio coverage system shall be capable of modification or expansion in the event frequency changes are required by the FCC or other radio licensing authority, or additional frequencies are made available by the FCC or other radio licensing authority.

510.4.2.7 Design documents. The fire code official shall have the authority to require "as-built" design documents and specifications for emergency responder communications coverage systems. The documents shall be in a format acceptable to the fire code official.

510.4.2.8 Radio communication antenna density. Systems shall be engineered to minimize the near-far effect. Radio enhancement system designs shall include sufficient antenna density to address reduced gain conditions.

Exceptions:

1. Class A narrow band signal booster devices with independent AGC/ALC circuits per channel.
2. Systems where all portable devices within the same band use active power control features.

510.5 Installation requirements. The installation of the public safety radio coverage system shall be in accordance with NFPA 1221 and Sections 510.5.1 through 510.5.4.

510.5.1 Approval prior to installation. Amplification systems capable of operating on frequencies licensed to any public safety agency by the FCC or other radio licensing authority shall not be installed without prior coordination and approval of the fire code official.

510.5.2 Minimum qualifications of personnel. The minimum qualifications of the system designer and lead installation personnel shall include both of the following:

1. A current FCC-issued general radiotelephone operator's license.
2. Certification of in-building system training issued by an approved organization or approved school, or a certificate issued by the manufacturer of the equipment being installed.

System design software with prediction tools are to be used in the design plan to give an accurate display of the overall design and RF propagation, e.g., IBwave, Ranplan. Design process shall include site surveys to collect pre and post installation data to validate predictions and ensure proper loss, gain, and power levels. A calibrated spectrum analyzer will be used to validate pre and post installation signal levels in dBm. Validations and loss, gain, power levels will be included in the completed As-Built documentation.

510.5.3 Acceptance test procedure. Where an emergency responder radio coverage system is required, and upon completion of installation, the building owner shall have the radio system tested to verify that two-way coverage on each floor of the building, critical areas will have 99 percent coverage and General areas will have 90 percent coverage. Critical areas must have their own grid in addition to 20 grids. (Elevator lobby, stair case, mechanical rooms). Test will be deemed failed if two or more adjacent grids do not meet the required signal level. Testing shall be conducted by personnel with the minimum qualifications as specified in Section 510.5.2. and shall be coordinated with the Harris County Universal Services Radio shop. The building owner shall retain all test records at the inspected premises and a copy submitted to the fire code official within 30 days of testing. If the system fails to comply with the minimum requirements of Harris County, repairs shall be made and additional testing conducted until the minimum requirements are met. The test procedure shall be conducted as follows:

1. Each floor of the building shall be divided into a grid of 20 approximately equal test areas up to 100,000 sq ft, for each additional 10,000 sq ft will add 5 grid locations.
2. The test shall be conducted using a calibrated and approved portable radio authorized by the fire code official and Harris County Universal Services radio shop.
3. Failure of more than one test area shall result in failure of the test.
4. In the event that two of the test areas fail the test, in order to be more statistically accurate, the floor shall be permitted to be divided into 40 equal test areas. Failure of not more than two nonadjacent test areas shall not result in failure of the test. If the system fails the 40-area test, the system shall be altered to meet the 95-percent coverage requirement.

5. A test location approximately in the center of each test area shall be selected for the test, with the radio enabled to verify two-way communications to and from the outside of the building through Harris County's radio communications system. Once the test location has been selected, that location shall represent the entire test area. Failure in the selected test location shall be considered failure of that test area. Additional test locations shall not be permitted.
6. The gain values of all amplifiers shall be measured and the test measurement results shall be kept on file with the building owner so that the measurements can be verified during annual tests. In the event that the measurement results become lost, the building owner shall be required to rerun the acceptance test to reestablish the gain values.
7. As part of the installation a spectrum analyzer or other suitable test equipment, calibrated within the previous 12 months, shall be utilized to ensure spurious oscillations are not being generated by the subject signal booster. This test shall be conducted at the time of installation and subsequent inspections.
8. Systems incorporating Class B signal-booster devices or Class B broadband fiber remote devices shall be tested using two portable radios simultaneously conducting subjective voice quality checks. One portable radio shall be positioned not greater than 10-feet (3048mm) from the indoor antenna. The second portable radio shall be positioned at a distance that represents the farthest distance from any indoor antenna. With both portable radios simultaneously keyed up on different frequencies within the same band, subjective audio testing shall be conducted and comply with DAQ levels as specified in Sections 510.4.1.1. and 510.4.1.2.

510.5.4 FCC compliance. The emergency responder radio coverage system installation and components shall also comply with all applicable federal regulations including, but not limited to, FCC 47 CFR Part 90.219.

510.6 Maintenance. The emergency responder radio coverage system shall be maintained operational at all times in accordance with Sections 510.6.1 through 510.6.4 and shall be replaced or repaired where defective. The property owner shall be responsible for necessary repairs, replacement, or upgrades to the system as directed by the fire code official. In addition, the property owner shall provide to the fire code official the names and phone numbers of all contact persons for the property.

510.6.1 Testing and proof of compliance. The owner of the building or owner's authorized agent shall have the emergency responder radio coverage system inspected and tested annually or where structural changes occur including additions or remodels that could materially change the original field performance tests. Testing shall consist of the following:

1. In-building coverage test as described in Section 510.5.3.
2. Signal boosters shall be tested to verify that the gain is the same as it was upon initial installation and acceptance or set to optimize the performance of the system.
3. Backup batteries and power supplies shall be tested under load of a period of 1 hour to verify that they will properly operate during an actual power outage. If within the 1-hour test period the battery exhibits symptoms of failure, the test shall be extended for additional 1-hour periods until the integrity of the battery can be determined.

4. Other active components shall be checked to verify operation within the manufacturer's specifications.
5. At the conclusion of the testing, a report, which shall verify compliance with Section 510.5.3, shall be kept on site and available for review by the fire code official. The fire code official shall be notified in writing of any changes to the emergency contact information.

510.6.2 Additional frequencies. The building owner shall modify or expand the emergency responder radio coverage system at his or her expense in the event frequency changes are required by the FCC or other radio licensing authority, or additional frequencies are made available by the FCC or other radio licensing authority. Prior approval of a public safety radio coverage system on previous frequencies does not exempt this section.

510.6.3 Nonpublic safety system. Where other nonpublic safety amplification systems installed in buildings reduce the performance or cause interference with the emergency responder communications coverage system, the nonpublic safety amplification system shall be corrected or removed.

510.6.4 Field testing. Agency personnel shall have the right to enter onto the property at any reasonable time to conduct field testing to verify the required level of radio coverage.

CHAPTER 9

FIRE PROTECTION SYSTEMS

SECTIONS 901.4.6, 901.4.6.1, 901.4.6.3, 901.4.6.4, 901.6.1, 902.1, 903.4.1, 903.4.2, 904.12.1, 907.2, 907.2.1, 907.2.1.1, 907.4.1, 907.5.2.1, 907.6.6, 912.6, 914.7.1 are amended to read as follows; SECTIONS 901.4.6.5, 903.2.13, 903.3.1.1.3, 903.4.2.1, 903.4.4, 903.7, 907.1.4, 907.2.1.3, 907.2.3.1, 907.2.6.4, 907.2.24, 907.6.2.1, 913.2.1.1, 913.6, 913.7, 913.8, 918 are added, to read as follows:

901.4.6 Pump and riser room size. Where provided, fire pump rooms and automatic sprinkler system riser rooms shall be designed with adequate space for all equipment necessary for the installation, as defined by the manufacturer, with sufficient working space around the stationary equipment. Clearances around equipment to elements of permanent construction, shall be sufficient to allow inspection, service, repair or replacement without removing such elements or permanent construction or disabling the function of a required fire-resistance-rated assembly. Fire pump and automatic sprinkler system riser rooms shall be provided with doors and unobstructed passageways large enough to allow removal of the largest piece of equipment. Sufficient clearances around equipment and permanent construction shall be maintained and kept free of storage and other obstructions.

901.4.6.1 Access. Automatic sprinkler system risers, fire pumps and controllers shall be provided with ready access. Where located in a fire pump room or automatic sprinkler riser room, the door shall be permitted to be locked provided that the key is available at all times. Fire sprinkler riser rooms shall have an exterior access door with a key box in accordance with Section 506 of this code

Exceptions: Automatic fire sprinkler control valves that are located on the exterior of the building, or in a vault, or in a *readily accessible* area outside of the building.

901.4.6.2 Marking on access doors. Access doors for automatic sprinkler system riser rooms and fire pump rooms shall be labeled with an approved sign. The lettering shall be in contrasting color to the background. Letters shall have a minimum height of 2 inches (51 mm) with a minimum stroke of 3/8 inch (10 mm).

901.4.6.3 Environment. Automatic sprinkler system riser rooms and fire pump rooms shall be maintained at a temperature of not less than 40°F (4°C) and other environmental requirements as specified by the manufacturer of the installed system. Heating units shall be permanently installed.

901.4.6.4 Lighting. Permanently installed artificial illumination on both interior and exterior sides of the access door shall be provided in the automatic sprinkler system riser rooms and fire pump rooms.

901.4.6.5 Fire Sprinkler Riser Room Separation. Automatic fire sprinkler riser rooms shall be separated from the remainder of the building by not less than a 1-hour fire barrier.

901.6.1 Standards. *Fire protection systems* shall be inspected, tested and maintained in accordance with the referenced standards listed in Table 901.6.1.

Table 901.6.1

FIRE PROTECTION SYSTEM MAINTENANCE STANDARDS

SYSTEM	STANDARD
Portable fire extinguishers	NFPA 10

Carbon dioxide fire-extinguishing system	NFPA 12
Halon 1301 fire-extinguishing system	NFPA 12A
Dry-chemical extinguishing systems	NFPA 17
Wet-chemical extinguishing systems	NFPA 17A
Water-based fire protection systems	NFPA 25
Fire alarm systems	NFPA 72
Mechanical smoke exhaust systems	NFPA 204
Smoke and heat vents	NFPA 204
Water-mist systems	NFPA 750
Clean-agent extinguishing systems	NFPA 2001
Aerosol fire-extinguishing systems	NFPA 2010
External remote fire hose connection	HC Fire Code 918

Section 903.3.1.1.3 Service main protection. Above ground piping for private service shall be protected from mechanical and fire damage with fire sprinklers or by enclosing in a 1-hour rated chase.

903.4.1 Monitoring. Alarms, supervisory and trouble signals shall be transmitted to an approved supervising station, through a dedicated function fire alarm control unit or a fire alarm control panel. Each alarm, supervisory, and trouble signal shall be addressable and identify the building, zone or riser location when initiated or activated. When approved by the County Building Code Official, a performance based alternative may be approved.

Exceptions:

1. Underground key or hub valves in roadway boxes provided by the municipality or public utility are not required to be monitored.
2. Backflow prevention device test valves located in limited area sprinkler system supply piping shall be locked in the open position. In occupancies required to be equipped with a fire alarm system, the backflow preventer valves shall be electrically supervised by a tamper switch installed in accordance with NFPA 72 and separately annunciated.

903.4.2 Alarms. An approved audible device, located on the exterior of the building in an *approved* location, shall be connected to each *automatic sprinkler system*. Such sprinkler waterflow alarm devices shall be activated by water flow equivalent to the flow of a single sprinkler of the smallest orifice size installed in the system. Where a fire alarm system is installed, actuation of the *automatic sprinkler system* shall actuate the building fire alarm system, and meet the requirements of 903.4.1 and 903.4.2.1. For buildings without a required fire alarm system, a sprinkler monitoring system meeting the requirements of 903.4.2.1 shall be provided.

903.4.2.1. Occupancy notification. Occupant notification shall be provided in accordance with Section 907.5 in all areas covered by the automatic sprinkler system.

Exception: ~~Occupant notification not required in~~ Group S Warehouse areas with no public access.

903.7 Required minimum safety pressure. A minimum pressure safety factor of 5 psi shall be added to all hydraulically calculated fire sprinkler pressure demands.

904.12.1 Manual system operation. A manual actuation device shall be located at or near a *means of egress* from the cooking area not less than 10 feet (3048 mm) and not more than 20 feet (6096 mm) from the kitchen exhaust system. The manual actuation device shall be installed not more than 48 inches (1200 mm) nor less than 42 inches (1067 mm) above the floor and shall clearly identify the hazard protected. The manual actuation shall require a maximum force of 40 pounds (178 N) and a maximum movement of 14 inches (356 mm) to actuate the fire suppression system. An unobstructed path of not less than 36 inches (915 mm) wide to the manual actuation device shall be maintained.

Exception: *Automatic sprinkler systems* shall not be required to be equipped with manual actuation means.

907.2 Where required—new buildings and structures. An *approved* fire alarm system installed in accordance with the provisions of this code and NFPA 72 shall be provided in new buildings and structures in accordance with Sections 907.2.1 through 907.2.23 and provide occupant notification in accordance with Section 907.5, unless other requirements are provided by another section of this code.

The automatic fire detectors shall be smoke detectors. Where ambient conditions prohibit installation of automatic smoke detection, other automatic fire detection shall be allowed.

All manual, automatic or manual and automatic fire alarm systems shall also include smoke detectors in each mechanical equipment, electrical, transformer, telephone equipment, corridors, lobbies, storage rooms larger than 200 square feet, elevator machine rooms, elevator lobbies, and other areas determined to be a special hazard by the County Fire Marshal.

Not fewer than one manual fire alarm box shall be provided in an approved location to initiate a fire alarm signal for fire alarm systems employing automatic fire detectors or waterflow detection devices. Where other sections of this code allow elimination of the fire alarm boxes due to sprinklers, a single fire alarm box shall be installed.

Exceptions:

1. The manual fire alarm box is not required for fire alarm systems dedicated to elevator recall control and supervisory service.
2. The manual fire alarm box is not required for Group R-2 occupancies unless required by the *fire code official* to provide a means for fire watch personnel to initiate an alarm during a sprinkler system impairment event. Where provided, the manual fire alarm box shall not be located in an area that is open to the public.

907.2.1 Group A. A manual fire alarm system that activates the occupant notification system in accordance with Section 907.5 shall be installed in Group A occupancies where the occupant load due to the assembly occupancy is 100 or more. Group A occupancies not separated from one another in accordance with Section 707.3.10 of the *International Building Code* shall be considered as a single occupancy for the purposes of applying this section, however, the occupant loads shall be combined where openings between fire areas create intervening spaces. Portions of Group E occupancies occupied for assembly purposes shall be provided with a fire alarm system as required for the Group E occupancy.

907.2.1.1 – System initiation in Group A occupancies with an occupant load of 300 or more. Activation of the fire alarm in Group A occupancies with an *occupant load* of 300 or more shall initiate a signal using an emergency voice/alarm communications system in accordance with Section 907.5.2.2

Exception: Where *approved*, the prerecorded announcement is allowed to be manually deactivated for a period of time, not to exceed 3 minutes, for the sole purpose of allowing a live voice announcement from an *approved*, constantly attended location.

907.2.1.3 – Group A-2. A manual fire alarm system shall be installed in all Group A-2 occupancies where alcohol is consumed.

907.2.3 Group E. A manual fire alarm system that initiates the occupant notification signal utilizing an emergency voice/alarm communication system meeting the requirements of Section 907.5.2.2 and installed in accordance with Section 907.6 shall be installed in Group E occupancies. Where *automatic sprinkler systems* or smoke detectors are installed, such systems or detectors shall be connected to the building fire alarm system.

Exceptions:

1. Emergency voice/alarm communication systems meeting the requirements of Section 907.5.2.2 and installed in accordance with Section 907.6 shall not be required in Group E occupancies with occupant loads of 100 or less, provided that activation of the manual fire alarm system initiates an approved occupant notification signal in accordance with Section 907.5.
2. Manual fire alarm boxes are not required in Group E occupancies where all of the following apply:
 - 3.1. Interior corridors are protected by smoke detectors.
 - 3.2. Auditoriums, cafeterias, gymnasiums and similar areas are protected by heat detectors or other approved detection devices.
 - 3.3. Shops and laboratories involving dusts or vapors are protected by heat detectors or other approved detection devices.
3. Manual fire alarm boxes shall not be required in Group E occupancies where all of the following apply:
 - 4.1. The building is equipped throughout with an approved automatic sprinkler system installed in accordance with Section 903.3.1.1.
 - 4.2. The emergency voice/alarm communication system will activate on sprinkler water flow.
 - 4.3. Manual activation is provided from a normally occupied location.

907.2.3.1 Pre-K areas in Group E occupancies. Smoke detection shall be provided in areas or rooms that can be occupied by Pre-K children.

907.2.6.4 Group I-4 occupancies.

907.2.6.4.1 Group I-4 All licensed daycare centers shall have a manual fire alarm system that initiates the occupant notification signal utilizing an emergency voice/alarm communication system meeting the requirements of Section 907.5.2.2 and installed in accordance with Section 907.6. When automatic sprinkler systems are installed, such systems shall be connected to the building fire alarm system. Smoke detection shall be provided in areas or rooms that can be occupied by children.

Exceptions: In Group I-4 occupancies an emergency voice/alarm communication system is not required when the facility occupancy load is 100 or less.

907.2.24 Alarm annunciation. Alarm annunciation/indication is required to be located at the main entrance of all buildings required to have an approved fire alarm system.

907.4.1 Protection of fire alarm control unit. -A single smoke detector shall be provided at the location of each fire alarm control unit, notification appliance circuit power extenders and supervising station transmitting equipment.

907.5.2.1 Audible alarms. Audible alarm notification appliances shall be provided and emit a distinctive sound that is not to be used for any purpose other than that of a fire alarm. All R-1 and R-2 sleeping units must have low frequency sounders installed per NFPA 72.

907.5.2.2.2 Live voice messages. The emergency voice/alarm communication system shall have the capability to broadcast live voice messages by paging zones on a selective and all-call basis. Emergency voice/alarm communication systems shall be programmed to return to the pre-recorded messaging or alarm signaling immediately following live voice messaging for continued occupant notification.

907.6.2.1 Fire Alarm Surge Protectors. Surge protection shall be provided on all fire alarm related components, to protect from transient voltage, including but not limited to the following: signaling line circuits (SLC), notification appliance circuits (NAC), telephone lines, AC power connections.

Section 907.6.6 Monitoring. Alarms, supervisory and trouble signals shall be transmitted to an approved supervising station, each alarm supervisory and trouble signal shall identify the building, room and location of the specific device that was initiated or activated. When approved by the County Fire Code Official, a performance-based alternative may be approved.

Exception: Monitoring by a supervising station is not required for:

1. Single- and multiple-station smoke alarms required by Section 907.2.10.
2. Smoke detectors in Group I-3 occupancies.
3. Automatic sprinkler systems in one- and two-family dwellings.

912.6 Backflow protection. The potable water supply to automatic sprinkler and standpipe systems shall be protected against backflow as required by the Local Water Authority.

913.2.1.1 Fire Pump Rooms. Each room where fire pumps are located shall have an exterior access door with a Key Box system compliant with 506.1 for fire department access. Illumination shall be provided on both the exterior and interior sides of the access door and the door shall be clearly marked and identified per Section 509.1. Storage rooms shall not be used for a fire pump room.

913.6 Water Supply for Fire Pumps: All fire pump installations where the fire pump is supplied directly from a water main or utility district water line shall include a break tank designed in accordance with NFPA 22 or provide an approval letter from the water authority authorizing direct connection to the water main provided with specified backflow prevention.

Exception: Performance-based alternative provided by a Civil Engineer, Fire Protection Engineer, or RME – G licensed by the State of Texas may be submitted for consideration by the Fire Code Official and Building Official.

913.7 Electrical outage history report. An electric service outage report shall be provided for all electrical fire pumps installations. The report shall come from the local utility provider and include a list of all electrical outages for a period of the past 24 months for the permitted address.

913.8 Standby power supply for fire pumps. Standby power supply is required for fire pump installations

in all buildings classified as Critical Facilities, and when required by the County Building Official after consideration of the occupancy classification. Such standby power supplies shall meet the requirements of Section 1203.2.19.

914.7.1 Automatic sprinkler system. Special amusement buildings shall be equipped throughout with an *automatic sprinkler system* in accordance with Section 903.3.1.1. Where the special amusement building is temporary, the sprinkler water supply shall be of an *approved* temporary means.

Exception 1: Automatic sprinklers are not required where the total floor area of a temporary special amusement building is less than 1,000 square feet (93 m²) and the *exit access* travel distance from any point to an *exit* is less than 50 feet (15 240 mm).

Exception 2: A temporary special amusement building constructed in accordance with Chapter 31 may seek approval of a performance-based alternative under Section 104.9.

SECTION 918

REMOTE FIRE HOSE CONNECTIONS

918.1 Remote fire hose connection. Where approved by the County Building Code Official or Fire Marshal remote fire hose connections may be installed as an alternative means of fire protection in accordance with Section 503.1.1, Exception 1.2.. For portions of buildings protected by remote fire hose connections in Groups F, S, and H occupancies, access doors shall be provided in accordance with Section 3206.6. of this code.

918.2 External remote fire hose connection. Remote fire hose connections shall be designed using a minimum of 4 inch(102mm) diameter galvanized steel pipe for up to 1,000 ft. (305 m), or 6 inch(152mm) diameter galvanized steel pipe for over 1,000 ft. (305 m) in length, or any other equivalent pipe material approved by the County Building Official. C900 pipe may be substituted for underground line as required per Harris County design standard. The fire department connection and fire hose connection thread shall be designated by the local responding fire department.

918.2.1 Installation. A 2-1/2 inch fire department connection and hose connection shall be a minimum height of 18 inches and a maximum of 48 inches, and installed within 10-ft of a fire department access door or means of egress if not fronting a fire lane access road.

918.2.2 Vehicle impact protection. Vehicle impact protection shall be provided in accordance with Section 312 of this code.

918.2.3 Signs and markings. External remote fire hose connections shall comply with Section 912 of this code. The fire department inlet connection sign shall read "DRY REMOTE FDC". The remote fire hose connection sign shall read "DRY REMOTE FIRE HOSE CONNECTION".

918.2.4 Locking Caps. Approved locking caps shall be provided for all remote hose connections.

External Remote Fire Hose Connection

FDC INLET CONNECTION SECTION DETAIL

FDC (Fire Dept. Connection)

LOCATED WITHIN 10' OF FIRE LANE
TO BE DETERMINED BY FIRE DEPT.

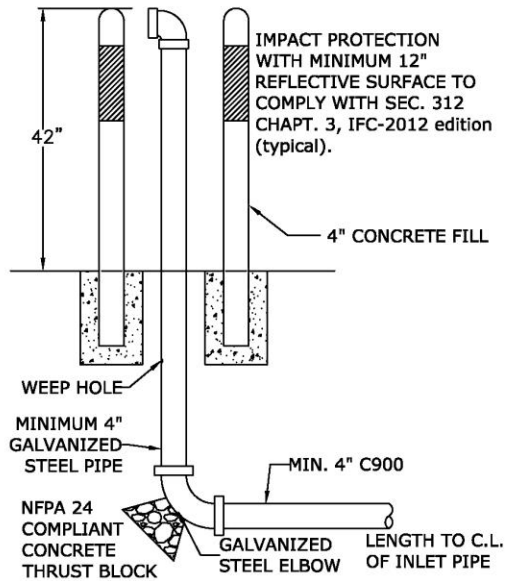

FDC OUTLET CONNECTION SECTION DETAIL

Y Connection

Two 2 1/2 Inch NPT
GATED OR VALVED

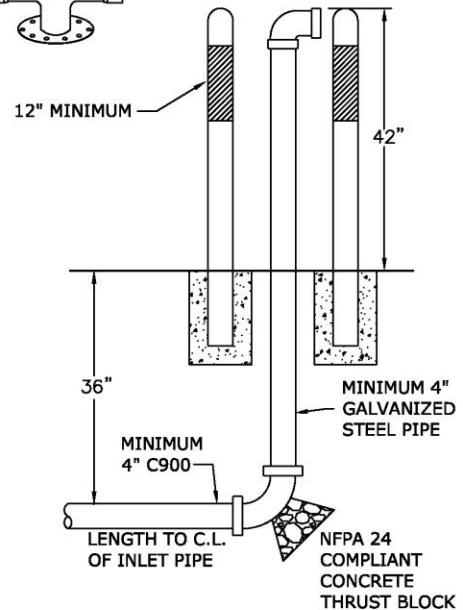

918.3 Piping protection. Piping that passes through the interior of the building shall comply with Section 905.4.1 of the International Building Code.

918.4 Remote fire hose connection location(s). Where approved by the Fire Code Official or Fire Marshal, remote fire hose connections shall be installed so that all portions of the building are covered within 150 ft. of fire hose lay. Fire department connection shall be located within 10 ft. of the fire lane.

Exception: Fire hose lay shall be increased up to 200 ft. when the building is protected with an automatic fire sprinkler system.

918.5 Maintenance, inspection, and testing. Remote fire hose connections shall be maintained, flow tested, and inspected annually. A written record shall be maintained and shall be made available to the fire code official.

CHAPTER 11

CONSTRUCTION REQUIREMENTS FOR EXISTING BUILDINGS

TABLE 1103.1 shall be modified as follows:

OCCUPANCY AND USE REQUIREMENTS^a

SECTION	USE				OCCUPANCY CLASSIFICATION																			
	High-rise	Atrium or covered mall	Under-ground building	Tire Storage	A	B	E	F	H-1	H-2	H-3	H-4	H-5	I-1	I-2	I-3	I-4	M	R-1	R-2	R-3	R-4	S	
1103.2	R	R	R	-	R	R	R	R	R	R	R	R	R	R	R	R	R	R	R	R	R	-	-	R
1103.3	R	-	R	-	R	R	R	R	R	R	R	R	R	R	R	R	R	R	R	R	R	-	-	R
1103.4.1	R	-	R	-	-	-	-	-	-	-	-	-	-	-	R	R	-	-	-	-	-	-	-	
1103.4.2	R	-	R	-	R	R	R	R	R	R	R	R	R	R	-	-	R	R	R	R	-	-	R	
1103.4.3	R	-	R	-	R	R	R	R	R	R	R	R	R	R	-	-	R	R	R	R	-	-	R	
1103.4.4	-	R	-	-	-	-	-	-	-	-	-	-	-	-	-	-	-	-	-	-	-	-	-	
1103.4.5	-	-	-	-	-	R	-	-	-	-	-	-	-	-	-	-	-	R	-	-	-	-	-	
1103.4.6	-	-	-	-	R	-	R	R	R	R	R	R	R	R	R	R	R	R	-	R	R	R	R	R
1103.4.7	-	-	-	-	R	-	R	R	R	R	R	R	R	R	R	R	R	-	R	R	R	R	R	R
1103.4.8	R	-	R	-	R	R	R	R	R	R	R	R	R	R	-	-	R	R	R	R	R	R	R	R
1103.4.9	R	-	-	-	-	-	-	-	-	-	-	-	-	-	R	-	-	-	-	-	-	-	-	
1103.5.1	-	-	-	-	R ^c	-	-	-	-	-	-	-	-	-	-	-	-	-	-	-	-	-	-	
1103.5.2	-	-	-	-	-	-	-	-	-	-	-	-	-	-	R	-	-	-	-	-	-	-	-	
1103.5.3	-	-	-	-	-	-	-	-	-	-	-	-	-	-	R ^b	-	-	-	-	-	-	-	-	
1103.5.4	-	-	-	-	R	R	R	R	R	R	R	R	R	R	R	R	R	R	R	R	R	R	R	R
1103.6.1	R	-	R	-	R	R	R	R	R	R	R	R	R	R	R	R	R	R	R	R	-	-	R	
1103.6.2	R	-	R	-	R	R	R	R	R	R	R	R	R	R	R	R	R	R	R	R	-	-	R	
1103.7.1	-	-	-	-	R ^d	-	-	-	-	-	-	-	-	-	-	-	-	-	-	-	-	-	-	
1103.7.2	-	-	-	-	-	-	R	-	-	-	-	-	-	-	-	-	-	-	-	-	-	-	-	
1103.7.3	-	-	-	-	-	-	-	-	-	-	-	-	-	R	-	-	-	-	-	-	-	-	-	
1103.7.4	-	-	-	-	-	-	-	-	-	-	-	-	-	-	R	-	-	-	-	-	-	-	-	
1103.7.5	-	-	-	-	-	-	-	-	-	-	-	-	-	-	-	R	-	-	-	-	-	-	-	
1103.7.6	-	-	-	-	-	-	-	-	-	-	-	-	-	-	-	-	-	-	R	-	-	-	-	
1103.7.7	-	-	-	-	-	-	-	-	-	-	-	-	-	-	-	-	-	-	-	R	-	-	-	
1103.7.8	-	-	-	-	-	-	-	-	-	-	-	-	-	-	-	-	-	-	-	-	-	R	-	
1103.8	-	-	-	-	-	-	-	-	-	-	-	-	-	R	-	-	-	-	R	R	R	R	-	
1103.9	R	-	-	-	-	-	-	-	-	-	-	-	-	R	R	-	R	-	R	R	R	R	-	
1104	R	R	R	-	R	R	R	R	R	R	R	R	R	R	R	R	R	R	R	R	R	R	R	R
1105	-	-	-	-	-	-	-	-	-	-	-	-	-	-	R	-	-	-	-	-	-	-	-	
1106	-	-	-	R	-	-	-	-	-	-	-	-	-	-	-	-	-	-	-	-	-	-	-	

R = The building is required to comply.

- a. Existing buildings shall comply with the sections identified as “Required” (R) based on occupancy classification or use, or both, whichever is applicable.
- b. Only applies to Group I-2 Condition 2 as established by the adopting ordinance or legislation of the jurisdiction.
- c. Only applies to Group A-2 occupancies where alcoholic beverages are consumed.
- d. Only applies to Group A-1 and A-2 occupancies where the occupant load is 300 or greater or where alcoholic beverages are consumed.

Section 1101.2.1 is added to read as follows:

1101.2.1 Applicability. All existing buildings, structures, facilities, or occupancies are subject to review and permitting under this chapter if:

1. The previous business or occupancy was issued a development permit after the original adoption of the Harris County Fire Code, January 1, 2005, received a certificate of compliance, and was closed, vacant, or not utilized for the intended purpose for more than 30 days, regardless if any construction is required to operate.
2. The business or occupancy has no record of being issued a development permit or a certificate of compliance regardless if any construction is required to operate.
3. If any construction takes place beyond maintenance of interior finishes such as painting walls, replacing floor coverings, etc. Any building of new walls, enclosing openings, changing the floor plan, etc. constitutes construction.

Existing occupancies that do not meet the definition of substantial improvement and have been permitted after the adoption of the Harris County Fire Code, January 1, 2005 and issued a Certificate of Compliance that has not closed or vacated for more than 30 days shall not be subjected to review under this chapter.

The fire code official has the authority to require compliance with this chapter on any existing building or structure in the interest of fire and life safety for the protection of the occupants of said building or structure.

SECTION 1103.5.1 is amended to read as follows:

1103.5.1 Group A-2. Where alcoholic beverages are consumed in a Group A-2 occupancy having an occupant load of 300 or more, the fire area containing the Group A-2 occupancy shall be equipped with an *automatic sprinkler system* in accordance with Section 903.3.1.1 and occupancy notification in accordance with Section 903.4.2.1.

A-2 occupancies that are separated in accordance with Section 706 or 707 of the International Building Code with fire doors or shutters, and share circulation between fire areas, shall be considered as one occupancy or area served, and for purposes of this section, the occupant load shall be based on the aggregate of the areas served.

1103.7.1 Group A-1 & A-2. A manual fire alarm system shall be installed in existing Group A-1 & A-2 Occupancies where the occupancy load is 300 or greater or where alcohol is being consumed in accordance with Section 907.2.1.

1103.7.2 Group E. A fire alarm system shall be installed in existing Group E occupancies in accordance with Section 907.2.3.

1103.7.3 Group I-1. An automatic fire alarm system shall be installed in existing Group I-1 facilities in accordance with Section 907.2.6.1.

Exception: Where each sleeping room has a means of egress door opening directly to an exterior egress balcony that leads directly to the exits in accordance with Section 1021, and the building

is not more than three stories in height.

1103.7.4 Group I-2. In Group I-2, an automatic fire alarm system shall be installed in accordance with Section 1105.9.

1103.7.5 Group I-3. An automatic and manual fire alarm system shall be installed in existing Group I-3 occupancies in accordance with Section 907.2.6.3.

1103.7.6 Group R-1. A fire alarm system and smoke alarms shall be installed in existing Group R-1 occupancies in accordance with Sections 1103.7.6.1 through 1103.7.6.2.1.

1103.7.6.1 Group R-1 hotel and motel manual fire alarm system. A manual fire alarm system that activates the occupant notification system in accordance with Section 907.5 shall be installed in existing Group R-1 hotels and motels more than three stories or with more than 20 sleeping units.

Exceptions:

1. Buildings less than two stories in height where all sleeping units, attics and crawl spaces are separated by 1-hour fire-resistance-rated construction and each sleeping unit has direct access to a public way, egress court or yard.
2. Manual fire alarm boxes are not required throughout the building where the following conditions are met:
 - 1.1 The building is equipped throughout with an automatic sprinkler system installed in accordance with Section 903.3.1.1 or 903.3.1.2.
 - 1.2 The notification appliances will activate upon sprinkler water flow.
 - 1.3 Not less than one manual fire alarm box is installed at an approved location.
3. Existing fire alarm systems that are compliant with the State Fire Marshal's Office rules and regulations and are not part of a substantial improvement repair or replacement.

1103.7.6.1.1 Group R-1 hotel and motel automatic smoke detection system. An automatic smoke detection system that activates the occupant notification system in accordance with Section 907.5 shall be installed in existing Group R-1 hotels and motels throughout all interior corridors serving sleeping rooms not equipped with an approved, supervised sprinkler system installed in accordance with Section 903.

Exception: An automatic smoke detection system is not required in buildings that do not have interior corridors serving sleeping units and where each sleeping unit has a means of egress door opening directly to an exit or to an exterior exit access that leads directly to an exit.

1103.7.6.2 Group R-1 boarding and rooming houses manual fire alarm system. A manual fire alarm system that activates the occupant notification system in accordance with Section 907.5 shall be installed in existing Group R-1 boarding and rooming houses.

Exception: Buildings less than two stories in height where all sleeping units, attics and crawl spaces are separated by 1-hour fire-resistance-rated construction and each sleeping unit has direct access to a public way, egress court or yard.

1103.7.6.2.1 Group R-1 boarding and rooming houses automatic smoke detection system. An automatic smoke detection system that activates the occupant notification system in accordance with Section 907.5 shall be installed in existing Group R-1 boarding and rooming houses throughout all interior corridors serving sleeping units not equipped with an approved, supervised sprinkler system installed in accordance with Section 903.

Exception: Buildings equipped with single-station smoke alarms meeting or exceeding the requirements of Section 907.2.11.1 and where the fire alarm system includes not less than one manual fire alarm box per floor arranged to initiate the alarm.

1103.7.7 Group R-2. A manual fire alarm system that activates the occupant notification system in accordance with Section 907.5 shall be installed in existing Group R-2 occupancies more than three stories in height or with more than 16 dwelling or sleeping units.

Exceptions:

1. Where each living unit is separated from other contiguous living units by fire barriers having a fire-resistance-rating of not less than $\frac{3}{4}$ hour, and where each living unit has either its own independent exit or its own independent stairway or ramp discharge at grade.
2. A separate fire alarm system is not required in buildings that are equipped throughout with an approved supervised automatic sprinkler system installed in accordance with Section 903.3.1.1 or 903.3.1.2 and having local alarm to notify all occupants.
3. A fire alarm system is not required in buildings that do not have interior corridors serving dwelling units and are protected by an approved automatic sprinkler system installed in accordance with Section 903.3.1.1 or 903.3.1.2, provided that dwelling units either have a means of egress door opening directly to an exterior exit access that leads directly to the exits or are served by open-ended corridors designed in accordance with Section 1027.6, Exception 3.
4. A fire alarm system is not required in buildings that do not have interior corridors serving dwellings units, do not exceed three stories in height and comply with both of the following:
 - 4.1 Each dwelling unit is separated from other contiguous dwelling units by fire barriers having a fire-resistance rating of not less than $\frac{3}{4}$ hour.
 - 4.2 Each dwelling unit is provided with hard wired, interconnected smoke alarms as required for new construction in Section 907.2.10.
5. Existing fire alarm systems that are compliant with the State of Texas rules and regulations and are not part of a substantial improvement repair or replacement.

1103.7.8 Group R-4. Please refer to Exhibit B, Section 428 of the Harris County Fire Code for additional information and Residential Board and Care design criteria.

CHAPTER 12
ENERGY SYSTEMS

SECTION 1203.1.8 is amended to read as follows:

1203.1.8 Group I-2 occupancies. In Group I-2 occupancies, where an essential electrical system is located in flood hazard areas per the Regulations of Harris County, Texas for Floodplain Management, and where new or replacement essential electrical system generators are installed, the system shall be located and installed in accordance with the Regulations of Harris County, Texas for Floodplain Management.

SECTION 1203.2 is amended to read as follows:

1203.2 Where required. Emergency and standby power systems shall be provided where required by Sections 1203.2.1 through 1203.2.19.

SECTIONS 1203.2.19, 1203.2.19.1, 1203.2.19.1.1, 1203.2.19.2, and 1203.2.19.2.1, are added, to read as follows:

1203.2.19 Critical facilities. Standby and emergency power. All facilities defined as *critical facilities* shall provide standby and emergency power.

1203.2.19.1 Standby power. A standby power system complying with this section and NFPA 70 shall be provided for standby power loads as specified in Section 1203.2.19.1.1.

1203.2.19.1.1 Standby power loads. The following loads are classified as standby power loads:

1. Smoke control system per Section 1203.2.17.
2. Ventilation and automatic fire detection equipment for smokeproof enclosures.
3. Electric fire pumps.
4. Standby power shall be provided for elevators per Section 1203.2.2 and in accordance with Section 3003 of the International Building Code.

1203.2.19.2 Emergency power. An emergency power system complying with this code and NFPA 70 shall be provided for emergency power loads as specified in Section 1203.2.19.2.1.

1203.2.19.2.1 Emergency power loads. The following loads are classified as emergency power loads:

1. Emergency voice/alarm communication systems per Section 1203.2.4.
2. Fire alarm systems.
3. Automatic fire detection systems.
4. Elevator car lighting.
5. Means of egress lighting and exit sign illumination per Section 1203.2.5 and as required by Chapter 10.

CHAPTER 28
LUMBER YARDS AND AGRO-INDUSTRIAL,
SOLID BIOMASS AND WOODWORKING FACILITIES

SECTIONS 2808.4, 2808.10 are amended to read as follows; **SECTIONS 2808.11 – 2808.14** are added to read as follows:

2808.4 Pile separation. Piles shall be separated from adjacent piles by 30 feet in all directions.

2808.10 Emergency plan. The *owner* or operator shall develop a plan for monitoring, controlling and extinguishing spot fires and submit the plan to the *fire code official* for review and approval, and distributed to the responding fire department for response planning. This plan shall include a site map showing all buildings, major storage, processing, and transfer areas, access roads, and fire protection features including fire lanes.

2808.11 Fire Protection. Firefighting water supplies and application accessories must be present and accessible, the desired amount and location to be approved by acceptance of the fire prevention plan. Examples of certain firefighting capabilities are:

1. Tank truck with the capacity of distributing firefighting water via hose and nozzle comparable to municipal fire department operations,
2. Fire hydrants within 1,000 feet,
3. Pond(s) with apparatus access and/or water distribution system in place,
4. Water distribution system capable of delivering a minimum of 60 psi and 250 gpm at all site distribution points.

2808.12 Site identification. Facility name and address shall be posted at main entrance and clearly visible from the street. 24-hour emergency contact number shall be posted at the main entrance and clearly visible from the street.

2808.13. Site Security. Public access shall be limited with fences in place and sufficient “No Trespassing” signage. Entry gates shall be at a minimum 14 feet wide and have sufficient turning radius for fire department access.

2808.14 Fire Prevention. Adequate fire prevention procedures, including no smoking or open flames outside designated areas, fire watch with extinguishers during hot work, and separation of combustible materials from sources of ignition.

CHAPTER 31
TENTS, TEMPORARY SPECIAL EVENT STRUCTURES
AND OTHER MEMBRANE STRUCTURES

SECTIONS 3105.6.1 and 3105.6.2 are amended to read as follows:

3105.6.1 Independent inspector. The *owner* of a temporary special event structure shall provide an as-built certificate from the design professional or employ a qualified, independent *approved* agency or individual to inspect the installation of a temporary special event structure.

3105.6.2 Inspection report. If owner employs an inspecting agency or individual, the owner shall furnish an inspection report to the *fire code official*. The inspection report shall indicate that the temporary special event structure was inspected and was or was not installed in accordance with the approved *construction documents*. Discrepancies shall be brought to the immediate attention of the installer for correction. Where any discrepancy is not corrected, it shall be brought to the attention of the *fire code official* and the designated responsible party.

CHAPTER 32

HIGH PILED COMBUSTIBLE STORAGE

SECTION 3201 is amended by the addition of Section 3201.5, to read as follows:

SECTION 3201.5 Required Specialized Engineered Plans. All high piled storage facilities shall be designed with the assistance of an engineer specializing in fire protection, licensed in the State of Texas.

CHAPTER 50

HAZARDOUS MATERIALS – GENERAL PROVISIONS

5001.7 is amended by the addition of Section 5001.7, to read as follows:

SECTION 5001.7 REQUIRED SPECIALIZED ENGINEERED PLANS. All Group H occupancies shall be designed with the assistance of an engineer specializing in fire protection, licensed in the State of Texas.

CHAPTER 56

EXPLOSIVES AND FIREWORKS

SECTIONS 5601.2.4.2, 5603.3, Table 5604.5.2(3), 5608.3, and 5609.1 are amended to read as follows and **Sections 5609.2 – 5609.5** have been added to read as follows:

5601.2.4.2 Fireworks display. The permit holder shall furnish a bond or certificate of insurance in an amount deemed adequate by the *fire code official* for the payment of all potential damages to a person or persons or to property by reason of the permitted display, and arising from any acts of the permit holder, the agent, employees or subcontractors. In accordance with the Texas Occupation Code, the applicant for any display shall submit evidence of a general liability insurance policy in the amount of \$1 million.

5603.3 Loss, theft or unauthorized removal. The loss, theft or unauthorized removal of *explosive materials* from a magazine or permitted facility shall be reported to the *fire code official*, local law enforcement authorities and the U.S. Department of Treasury, Bureau of Alcohol, Tobacco, Firearms and Explosives within 24 hours.

Exception: Loss of Division 1.4G (consumer fireworks) need not be reported to the Bureau of Alcohol, Tobacco, Firearms and Explosives but shall be reported to the fire code official.

TABLE 5604.5.2(3)

TABLE OF DISTANCES (Q-D) FOR BUILDINGS AND MAGAZINES CONTAINING EXPLOSIVES—DIVISION 1.4^c

QUANTITY OF DIVISION 1.4 EXPLOSIVES (NET EXPLOSIVES WEIGHT)		DISTANCES IN FEET			
Pounds over	Pounds not over	Inhabited Building Distance (IBD)	Distance to Public Traffic Route (PTR)	Intermagazine Distance ^{a, b} (IMD)	Intraline Distance (ILD) or Intraplant Distance ^a (IPD)
50	Not Limited	50	50	50	50

For SI: 1 foot = 304.8 mm, 1 pound = 0.454 kg.

a. A separation distance of 100 feet is required for buildings of other than Type I or Type II construction as defined in the *International Building Code*.

b. For earth-covered magazines, specific separation is not required.

1. Earth cover material used for magazines shall be relatively cohesive. Solid or wet clay and similar types of soil are too cohesive and shall not be used. Soil shall be free from unsanitary organic matter, trash, debris and stones heavier than 10 pounds or larger than 6 inches in diameter. Compaction and surface preparation shall be provided, as necessary, to maintain structural integrity and avoid erosion. Where cohesive material cannot be used, as in sandy soil, the earth cover over magazines shall be finished with a suitable material to ensure structural integrity.

2. The earth fill or earth cover between earth-covered magazines shall be either solid or sloped, in accordance with the requirements of other construction features, but not less than 2 feet of earth cover shall be maintained over the top of each magazines. To reduce erosion and facilitate maintenance operations, the cover shall have a slope of 2 horizontal to 1 vertical.

c. Restricted to articles, including articles packaged for shipment, that are not regulated as an explosive under Bureau of Alcohol, Tobacco, Firearms and Explosives regulations, or unpacked articles used in process operations that do not propagate a detonation

or deflagration between articles.

5604.5.2.3 Fireworks 1.4G. Where magazines containing 1.4g fireworks cannot meet the 50' separation inter-magazine distance, only 2 magazines will be allowed on same property.

5608.3 Approved fireworks displays. *Approved* fireworks displays shall include only the *approved* fireworks 1.3G, fireworks 1.4G, fireworks 1.4S and pyrotechnic articles 1.4G, which shall be handled by an *approved*, competent operator licensed by the State of Texas. The *approved* fireworks shall be arranged, located, discharged and fired in a manner that will not pose a hazard to property or endanger any person.

5609.1 General. The sale, storage, and display of Fireworks 1.4G is subject to the authority of the fire code official, including the authority to inspect, determine the presence of fire hazards.

5609.1.1 Applicability. This Section 5609 provides standards for the design and construction of buildings in which Fireworks 1.4G are to be stored, sold, or displayed. Such design and construction shall comply with this section and the Texas Fireworks Rules, current edition, as promulgated by the Texas State County Fire Marshal.

5609.1.2 Compliance with Fire Code. All structures used for the storage or sale of consumer fireworks 1.4G shall comply with the applicable provisions of the Harris County Fire Code for new structures, and with applicable sections of this sub-section.

5609.1.3 Fire Code Permit and Inspections. Any structure that is erected, occupied, or moved into or within the jurisdiction is considered new construction and requires a Fire Code permit and an inspection to ensure compliance with the adopted code.

5609.2 Definitions.

5609.2.1 Temporary Structure. Any structure that is erected, occupied, or moved into or within the jurisdiction, for a period of less than 180 days.

5609.2.2 Permanent Structure. Any structure that is erected, or moved into or within the jurisdiction, for a period of more than 180 days.

5609.2.3 Fireworks Control Area. Spaces within a building where quantities of fireworks 1.4G, not exceeding the maximum allowable quantities, are stored, dispensed, used or handled.

5609.3 Conflict between provisions. If there is a conflict between the provisions of this section and the Fireworks Rules, the more stringent of the provisions shall apply.

5609.3.1 Limit of authority. This section does not limit the authority of the County Fire Marshal to inspect any retail site location or storage facility to require additional fire protection measures.

5609.4 Requirements for all retail sales, displays, and storage sites and facilities. All Fireworks 1.4G retail sales sites, storage buildings, and control areas, including temporary storage facilities such as trailers, semi-trailers, or metal shipping containers must conform to the minimum standards of this section.

5609.4.1 Physical Address and Emergency Contact. All retail sales sites and storage facilities must have the physical address and a 24-hour emergency contact number prominently posted on the outside of each site, close to the main entrance, in numbers at least 4 inches in height and ½ inch stroke in width on a contrasting background, and visible from the street or road fronting the property.

5609.4.2 Residential Storage. Fireworks 1.4G retail storage buildings shall not be used for residential occupancies. Use of a residential building for the storage of fireworks in excess of 125 pounds of pyrotechnic material shall be considered a change in occupancy.

5609.4.3 Maximum allowable quantity. No more than 125 pounds of pyrotechnic material may be stored and/or displayed in any control area. In the absence of documentation approved by the fire code official, 25 percent of the gross weight of the fireworks, including all packaging, will be used to determine the 125 pound limitation.

Exception:

1. The maximum allowable quantities can be increased 100 percent if the building is equipped throughout with an automatic sprinkler system in accordance with Section 903.
2. The maximum allowable quantities may be greater than allowed by this section, subject to approval by the County Fire Marshal, if the building meets all requirements for a Group H-3 occupancy and Section 5609.4.

The aggregate quantity in use and storage shall not exceed the quantity listed for storage in the Application for Permit.

5609.4.4 Minimum separation distances. Except as specified elsewhere in this section, structures shall be located in accordance with the requirements of Table 5609.2.1.5.

Exceptions:

1. Trailers, semi-trailers, and metal containers used for storage only must be separated by at least 50 ft. from any building or structure other than other trailers, semitrailers, or metal shipping containers. There is no minimum distance between multiple trailers or semi-trailers when used for storage only.
2. Permanent facilities permitted before January 1, 2019 may be separated from adjacent buildings by less than 20 ft. if they are separated by a wall with a 1-hour fire resistance rating, provided existing facilities are not enlarged or expanded.
3. Where multiple firework retail stands are on a single property, separation shall be no less than 10 ft. Firework retail stands can be joined together with no separation if stands do not exceed 70 ft. in length.

Table 5609.4.1 Minimum Separation Distances of Fireworks 1.4G Retail Sales Buildings, including Trailers, Semi-trailers, and Metal Shipping Containers

Type of Structure	Minimum Distance
From other trailers or semi-trailers	0 ft.
From Vehicles	10 ft.
From other buildings	20 ft.
From Combustibles	30 ft.
From cooking equipment of any type, or any open flame equipment	50 ft.
Motor Vehicle fuel-dispensing station dispensers or Retail propane-dispensing station dispenser	100 ft.

5609.4.5 Electrical Work. Electrical work performed must be installed in accordance with the National Electrical Code.

5609.4.5.1 Required Listing. All electrical equipment, battery-powered equipment, and electrical cords shall be listed and shall be used in accordance with their listing.

5609.4.5.2 Temporary Power. The fire code official is authorized to give permission to temporarily supply and use power for up to 180 days. All temporary conductors shall comply with the National Electrical Code.

5609.4.5.3 Light fixture guards. All incandescent light fixtures within 25 ft. of any consumer fireworks shall have metal or plastic guards. All fluorescent light fixtures within 25 ft. of any consumer fireworks shall have plastic tube guards with caps or metal guards or plastic lens covers.

5609.4.5.4 Portable generators. Portable generators supplying power to consumer fireworks retail sales facilities shall comply with this section.

5609.4.5.4.1 Location distance. Portable generators shall be located not less than 10 ft. from the consumer fireworks retail sales facility and in an area free from grass, trash, and other combustible flammable materials.

5609.4.5.4.2 Surplus fuel. Generator fuel shall be stored in an approved safety container at least 10 ft. from the consumer fireworks retail sales facility. Fuel quantity shall be limited to not more than 10 gal.

5609.4.5.4.3 Extinguisher. For all generators a minimum 6 B.C. fire extinguisher shall be provided within 75 feet travel distance from generator location.

5609.4.6 Means of Egress. Means of egress including, but not limited to aisles, doors, and exit discharge, shall be clear at all times when the facility or the building is occupied.

5609.4.6.1 Number of exits. Each retail fireworks stand less than 16 feet in length shall have at least one walk door which opens outward, in a location approved by the fire code official. Stands measuring 16 feet or longer must have at least two walk doors which open outward, in locations approved by the fire code official.

5609.4.6.2 Maximum travel distance. Exits provided for all fireworks retail sales stands shall be arranged so that the maximum egress travel distance does not exceed 35 ft.

5609.4.6.3 Exit door requirements. The minimum dimensions of any walk door are 28 inches wide X 72 inches high. Walk doors must not be locked from the outside when the stand is occupied, and must be immediately accessible from the inside.

5609.4.6.4 Minimum aisle width. A minimum distance of six feet shall be maintained from the front of the customer counter to the back side of the stand. The minimum clear exit aisle width is 28 inches.

5609.4.7 Fire Protection. All Fireworks 1.4G retail stands must comply with this section.

5609.4.7.1 Smoke detectors. Each stand will have an operational smoke detector in each sales area. If sleeping or rest areas are provided in the stand, there must be one smoke detector in each sales area and one in each sleeping or rest area.

5609.4.7.2 Cooking equipment. Cooking equipment of any type, or any open-flame equipment, shall not be permitted within 50 ft. of all stands, trailers, or shipping containers used for the storage or sale of consumer fireworks.

5609.4.7.3 Retail stand fireworks control areas. In Fireworks 1.4G retail stands, a flame break approved by the fire code official, may be installed every 8-10 feet to establish retail stand fireworks control areas. No more than 125 lbs. of pyrotechnic material may be stored and/or displayed in any retail stand fireworks control area.

5609.4.7.4 Approved flame break. An approved flame break, of not less than 3/4 inch plywood, shall be used to separate retail stand fireworks control areas. Separation shall begin at the back wall and extend to the furthest shelf point, and from the floor to the underside of roof. Fire caulking shall be applied at all penetrations and adjoining points along the 3/4 inch plywood separation.

5609.5 Specific requirements for retail fireworks sites other than stands. All indoor retail fireworks sites and storage facilities, other than stands, shall comply with the requirements of this section.

5609.5.1 Building Design. The retail fireworks sales building shall be a free standing, durable structure with no basement, and only one story of space accessible to the public.

5609.5.2 Multi-use building prohibited. The fireworks sales area shall not be part of a multi-use or multi-tenant building, except that office areas and restrooms ancillary to the building are allowed if:

1. Offices and related spaces are separated from fireworks storage or sales areas by fire barriers having a fire resistance rating of not less than 1 hour; and
2. Window openings in the fire barrier wall are protected by self-closing fire doors or fixed fire windows having a fire protection rating of not less than 3/4 hour, and installed in accordance with NFPA 80, Standard for Fire Doors and Fire Windows.

5609.5.3 Assembly and educational occupancies prohibited. Assembly or educational occupancies cannot be used for the storage or sale of fireworks 1.4G.

5609.5.4 Application, Plans, Approval, Permits. All newly constructed firework retail sites other than stands shall comply with the adopted Harris County Fire Code Regulation and all processes shall be followed for plan submittal, approval, permitting, and inspection.

5609.5.5 Emergency response plan. The operator of each indoor retail sales site or

storage facility shall prepare a written emergency response plan in accordance with Chapter 4 of this Code. The evacuation plan shall be posted in a conspicuous location that is accessible to the public as well as to persons employed or otherwise working in the facility.

5609.5.6 Maximum occupant load. The approved maximum occupant load shall be conspicuously posted near the main entrance using a format approved by the fire code official. Records of occupant load will be maintained onsite and available for inspection by the fire code official.

5609.5.7 Means of Egress. All means of egress in consumer fireworks retail sales facilities, other than stands, shall comply with the applicable requirements of this section.

5609.5.7.1 Minimum number of exits. The minimum number of exits provided from the retail sales area shall be not less than three, or more as determined in accordance with this Code.

5609.5.7.2 Maximum travel distance. Exits provided for the retail sales area of consumer fireworks retail sales facilities, other than stands, shall be located so that the maximum egress travel distance, measured from the most remote point to an exit along the natural and unobstructed path of egress travel, does not exceed 75 ft.

5609.7.3 Minimum aisle width. Aisles shall have a minimum clear width of 48 inches. Aisles and exit doors shall be kept free of any obstruction.

5609.7.4 Minimum exit door width. The minimum egress door width shall be not less than 36 inches in width and will provide a minimum clear opening width of 32 inches.

5609.7.5 Egress door swing. Unless approved by the County Fire Marshal, all egress doors shall be of the side- hinge swinging type and shall be arranged to swing in the direction of egress travel.

5609.7.6 Panic Hardware. Every egress door that has a latching device shall be provided with approved panic hardware.

5609.7.7 Roll-up, or lift doors. Roll-up or lift doors may be used as egress doors when there is a readily distinguishable device that secures each door in the open position whenever the building is occupied.

5609.5.8 Sales area design. Fireworks sales display areas shall be sufficiently designed to prevent customers from handling fireworks, unless an attendant is directly assisting the customer.

5609.5.8.1 Visual Supervision. The sales area shall be designed and constructed so that fireworks shall be under the visual supervision of a store employee or other responsible party while the store is open to the public.

5609.5.8.2 Height counter and displays. Partitions, counters, shelving, cases, displays, product and similar sales areas shall not exceed 6 ft. in height above the floor surface inside the perimeter of the retail sales area.

5609.5.8.3 Height perimeter. Where located along the perimeter of the retail

sales area, the maximum height of sales displays, shelving, and product shall be limited to 12 ft.

5609.5.9 Fire protection.

5609.5.9.1 Fire Extinguishers. Portable fire extinguishers shall be specified as required for extra (high) hazard occupancy in accordance with NFPA 10, Standard for Portable Fire Extinguishers.

5609.5.9.1.1 Number and Placement. Every indoor retail sales building shall have not less than two portable fire extinguishers with a minimum 2A rating. At least one approved Class A fire extinguisher shall be provided for each 1,000 square feet of floor space, not to exceed 75 ft. travel distance.

5609.5.9.2 Fire alarm system. A fire alarm system, installed in accordance with NFPA 72, shall be required in all consumer fireworks retail sales facilities. Facilities less than 3,000 sq. ft. in area AND in existence and continuously permitted before January 1, 2005 are exempt from compliance, provided such facilities are not enlarged or expanded beyond their January 1, 2005 operation.

5609.5.9.3 Automatic fire sprinklers. An automatic sprinkler system shall be required in all consumer fireworks retail sales facilities. Facilities less than 6,000 sq. ft. in area AND in existence and continuously permitted before January 1, 2005 are exempt from compliance, provided such facilities are not enlarged or expanded beyond their January 1, 2005 operation.

5609.5.9.4 Smoke Control. All sites must have a minimum average ceiling height of 12 ft. Smoke and heat vents designed and installed in accordance with NFPA 204, Standard for Smoke and Heat Venting shall be provided in consumer fireworks storage buildings. Facilities less than 50,000 sq. ft. in area AND in existence and continuously permitted before January 1, 2005 are exempt from compliance, provided such facilities are not enlarged or expanded beyond their January 1, 2005 operation.

5609.5.10 Other codes, standards, and laws. Unless specifically outlined in this chapter, all retail fireworks sites shall comply with the other applicable chapters of this code, the Texas Occupations Code 2154, Texas Local Government Code 352, and the Texas Fireworks Rules.

CHAPTER 80
REFERENCE STANDARDS

CHAPTER 80 is amended to read as follows:

The opening paragraph to **CHAPTER 80** is amended as follows:

This chapter lists the standards that are referenced in various sections of this document. The standards are listed herein by the promulgating agency of the standard, the standard identification, effective date and title, and the section or sections of this document that reference the standard. If the State of Texas has adopted any of the listed standards, the more stringent and/or more current standard of the provisions shall apply.

CHAPTER 80 is amended to include the following reference standards:

- a. NFPA 1, Uniform Fire Code—Current State adopted edition, Section 20.5
- b. NFPA 101[®] Life Safety Code[®]— Current State adopted edition, Chapter 33

APPENDIX B

FIRE-FLOW REQUIREMENTS FOR BUILDINGS

SECTION B103.3 is amended to read as follows:

B103.3 Areas without water supply systems. For information regarding water supplies for fire-fighting purposes in rural and suburban areas in which adequate and reliable water supply systems do not exist, the *fire code official* is authorized to use standards as established by Harris County.

EXHIBIT B

ADDITIONS, INSERTIONS, DELETION AND CHANGES TO INTERNATIONAL BUILDING CODE 2018 EDITION

CHAPTER 3 SECTION 308.3.3 has been added to read as follows:

SECTION 308.3.3 Six to 16 persons receiving custodial care. Refer to Section 428.

CHAPTER 3 SECTION 310.5 has been amended to read as follows

SECTION 310.5 Residential Group R-4. Refer to Section 428.

CHAPTER 4

SPECIAL DETAILED REQUIREMENTS BASED ON USE AND OCCUPANCY

Section 403.4.7 is amended to read, **Smoke removal for floors more than 75 feet above the lowest level of fire department vehicle access.**

Section 428 is added as follows:

SECTION 428

RESIDENTIAL BOARD AND CARE OCCUPANCIES

428.1 General. Residential Board and Care Occupancies as defined by 428.2 shall meet the provisions of Sections 428.3 through 428.5.

428.2 Definition. An existing residential occupancy, converted to be used for lodging and boarding of at least four but not more than 16 residents, not related by blood or marriage to the directors, owners or operators, for the purpose of providing personal care services. A Residential Board and Care Occupancy includes, but is not limited to:

- Alcohol and drug centers
- Assisted living facilities
- Congregate care facilities
- Convalescent facilities
- Detoxification facilities
- Family home
- Foster family homes
- Group homes
- Hospices
- Limited care facilities
- Personal care facilities
- Residential AIDS hospices
- Residential treatment home
- Social rehabilitation facilities
- Special residential care facility

For the purposes of this Code, a facility such as the above in a residential setting, housing at least four and **not more than 16 persons** shall be classified as a Commercial Establishment: **Residential Board and Care, Small** and shall comply with the provisions of the current State adopted editions of Section 20.5 of the Uniform Fire Code, NFPA 1 Chapter 33 of NFPA 101 Life Safety Code, or applicable State and Federal

requirements. If there is a conflict between the provisions of this section and the State or Federal requirements, rules, and regulations, the more stringent of the provisions shall apply.

For the purposes of this Code, a facility such as the above, housing **more than 16 persons** shall be classified as a Commercial Establishment: **Residential Board and Care, Large** and shall comply with the provisions of the current edition of the Harris County Fire Code, or applicable State and Federal requirements. If there is a conflict between the provisions of this section and the State or Federal requirements, rules, and regulations, the more stringent of the provisions shall apply.

428.3 Design. The applicable code requirements for a Residential Board and Care Facility depend on two factors; (1) the number of residents and (2) the ability of occupants to self-evacuate within three minutes. An RBC is not allowed in a multi-family dwelling or mixed use occupancy unless the entire building is classified as an Institutional Group I Occupancy.

Code requirements for Residential Board and Care conversions shall be per Table 428.3 and per Sections 428.3 through 428.5.

Table 428.3
Code Requirements for New RBC Conversions

	4 – 8 residents ^a	9-16 residents ^a	More than 16 residents ^a
Capable of self-preservation ^b	RBC-8A ^d	RBC-16A ^d	I-1 ^e
Not capable of self-preservation ^c	RBC-8B ^d	RBC-16B ^d	I-2 ^e
Sprinkler requirements	NFPA 13D	NFPA 13D	NFPA 13
Fire alarm requirements ^f	NFPA 72	NFPA 72	NFPA 72
<p><i>a. Maximum number of residents authorized on license. If not licensed, RBC-16B requirements shall apply.</i></p> <p><i>b. All residents have ability to move as a group to safety within 3 minutes or less. Classified by TDFPS as “Basic” service level. Classified by TDADS as Type A residents.</i></p> <p><i>c. One or more residents do not have the ability to move as a group to safety within 3 minutes or less. Classified by TDFPS as “Moderate”, “Specialized”, or “Intense” service level. Classified by TDADS as Type B residents.</i></p> <p><i>d. NFPA 1, Uniform Fire Code—Current state adopted Edition, Section 20.5 and NFPA 101[®] Life Safety Code[®]—Current state adopted Edition, Chapter 33</i></p> <p><i>e. International Fire Code—2015 Edition</i></p> <p><i>f. All Fire Alarm Systems shall meet the requirements of an automatic fire alarm system per NFPA 72.</i></p>			

428.3.1 Residential Board and Care, Small Building Design. The building design shall be per the current State adopted editions of NFPA 1, Uniform Fire Code, Section 20.5 and NFPA 101 Life Safety Code, Chapter 33.

428.3.2 Residential Board and Care, Large Building Design. The building design shall be per current adopted Fire Code.

428.4 Automatic sprinkler systems. Automatic sprinkler systems shall be provided in accordance with Sections 428.4.1 and 428.4.2.

428.4.1 Residential Board and Care, Small Sprinkler System Design. The sprinkler design shall be an NFPA 13D system.

428.4.2 Residential Board and Care, Large Sprinkler System Design. The sprinkler design shall be

an NFPA 13 system.

428.5 Fire alarm systems. The fire alarm system design (for Residential Board and Care Small and Large Occupancies) shall be per NFPA 72.

CHAPTER 5

GENERAL BUILDING HEIGHTS AND AREAS

Table 508.4 is amended to include footnote “g” as follows:

Group B occupancies are not required to be separated from Group F-2, S-2, or U occupancies, unless required by the Building Official or Fire Code Official.

CHAPTER 10
MEANS OF EGRESS

**Table 1004.5 is amended to include the following category and occupant load factor under
“Assembly”:**

Escape/Panic gaming rooms – 11 net.

CHAPTER 31
SPECIAL CONSTRUCTION

SECTION 3110 is amended to read as follows:

SECTION 3110
AUTOMATIC VEHICULAR GATES

3110.1 General. *Automatic vehicular gates* shall comply with the requirements of Sections 3110.2 through 3110.4 and other applicable sections of this code.

3110.2 Vehicular gates intended for automation. *Vehicular gates* intended for automation shall be designed, constructed and installed to comply with the requirements of ASTM F2200.

3110.3 Vehicular gate openers. *Vehicular gate* openers, where provided, shall be *listed* in accordance with UL 325.

3110.4 Required Hardware. Where electrically operated vehicular gates are used they shall include all of the following,

3110.4.1 Manual Override. All electrically operated vehicular gates shall be equipped with a manual override or fail-safe system. Manual override and fail-safe systems shall be located on the same side and as near to the Emergency Access Activation Point (EAAP) as possible, or may be included inside or at the EAAP. Electronic or battery backup systems will be considered for use for manual override or fail-safe systems. The manual override and fail-safe systems shall be subject to approval by the Fire Code Official.

3110.4.1.1 EAAP. The EAAP shall be located on the outside of the project and near the primary entrance either near the reader or gate access control box or on a post near the entrance gate. The EAAP shall not exceed a height of 5 feet. The EAAP shall provide an electric switch, toggle, micro-switch with button or key toggle electric switch. Key switch is preferred and will be subject to approval by the Fire Code Official

3110.4.2 Key Switch or Lock Box. All gates shall have an approved key switch (preferred) or lock box and shall be located as to provide immediate access from responding emergency vehicles.

3110.4.3 Keypad or Card Access. Pedestal type keypads or card systems or curb type dividers shall not interfere with emergency vehicle access.